



Scalla

Cluster Management Service Configuration Reference

6-June-2011

Andrew Hanushevsky



Scalla: Structured Cluster Architecture for Low Latency Access
©2003-2011 by the Board of Trustees of the Leland Stanford, Jr., University
All Rights Reserved
Produced under contract DE-AC02-76-SFO0515 with the Department of Energy
This code is available under a BSD-style license allowing minimally restricted use.

1	Introduction	5
1.1	Directives and Components	9
1.1.1	Clusters with 64 or fewer data servers.....	9
1.1.2	Clusters with 65 or more data servers	11
1.1.3	Frequently asked questions	14
1.2	Created Files.....	16
1.3	Starting the cmsd Process	17
1.3.1	Running multiple cmsd's on the same host	20
1.3.2	Using the StartCMS Script to Start cmsd	21
1.3.3	Using the StopCMS Script to Stop cmsd	22
2	Mandatory Configuration Directives	23
2.1	manager	23
2.2	role	25
2.2.1	Role Summary Table	26
3	Common Configuration Directives.....	29
3.1	adminpath	29
3.2	allow	30
3.3	defaults (an oss directive)	31
3.4	dfs	33
3.5	export	37
3.6	localroot (an oss directive)	39
3.7	perf.....	40
3.8	prep.....	43
3.8.1	Optional Prepare Interface Program Requirements	45
3.9	sched.....	49
3.10	seclib.....	52
3.11	space.....	53
3.12	space (an oss directive).....	55
4	Esoteric Configuration Directives	57
4.1	conwait.....	57
4.2	delay	59
4.3	fxhold	63
4.4	fsxeq.....	65
4.5	namelib (an oss directive)	67
4.6	nowait	68
4.7	osslib (an ofs directive).....	69
4.8	pidpath.....	70

4.9	ping.....	71
4.10	prepmsg	73
4.11	remoteroot (an oss directive).....	75
4.12	repstats	76
4.13	request.....	77
4.14	trace	78
4.15	xmilib.....	79
5	The Composite Cluster Name Space.....	81
5.1	Establishing a Composite Name Space.....	81
5.1.1	Frequently asked questions	84
5.2	Maintaining a Simple Server Inventory.....	85
5.3	XrdCnsd Program	87
5.3.1	Created Files	90
5.4	Listing Differences with cns_ssi diff.....	91
5.5	Listing the inventory with cns_ssi list.....	93
5.6	Updating the inventory with cns_ssi updt.....	95
6	Document Change History	97

1 Introduction

This document describes **Cluster Management Service Distributed** configuration directives. This component provides dynamic load balancing of files and name-space consolidation of distributed data regardless of location. The **cms** component is meant to be used with **xrootd**'s **Open File System (ofs)** component. Refer to the "**xrootd ofs & oss Configuration Guide**" for detailed information.

Directives for **cmsd**, the clustering daemon and its client counterpart used by the **ofs** component, come from a configuration file. The characters "**cms**" must prefix each directive in the configuration file. Directives that apply to multiple components must be preceded by the characters "**all**". This makes **cms** directives compatible with the **xrootd**'s other configurable components:

Component	Purpose
acc	Access control (i.e., authorization)
cms	Cluster Management Service
ofs	Open file system coordinating acc , cms , & oss components
oss	Open storage system ¹ (i.e., file system implementation)
sec	Security authentication
xrd	Extended request daemon.
xrootd	xrootd protocol.
all	Applies the directive to all of the above components.

Records that do not start with a recognized identifier are ignored. This includes blank record and comment lines (i.e., lines starting with a pound sign, #). This guide documents the **all** and **cms** configuration directives (i.e., the un-shaded rows). Other directives are documented in supplemental guide specific to the component they deal with.

The location of the configuration file is specified on the command line. Because each component has a unique prefix, a common configuration file can be used for the whole system.

Refer to the manual "**Configuration File Syntax**" on how to specify and use conditional directives and set variables. These features are indispensable for complex configuration files usually encountered in large installations.

¹ Certain **oss** directives are recognized and honored by **cmsd**.

A configuration file is mandatory, even if nothing is specified in it. Because load balancing is sensitive to other configuration options, the **cmsd** does not recognize certain specific directives that start with the **oss** prefix. This allows the use of a single configuration file without the need to duplicate directives. The **cms** prefix, applies directives specifically to the Cluster Management Service and no other component. Additionally, directives prefixed by “**all**” also apply to the Cluster Management Service.

Clustering is performed by a set of cooperating servers. One or more **cmsd** daemons run in manager mode and can be used by one or more **xrootd**'s to determine where to redirect a client's file open request. The request can only be redirected to a machine that is running a **cmsd** in server or supervisor mode. There can be up to 64 **cmsd** servers. Each machine can run one or more **xrootd**'s. The following figure illustrates a simple minimal system.

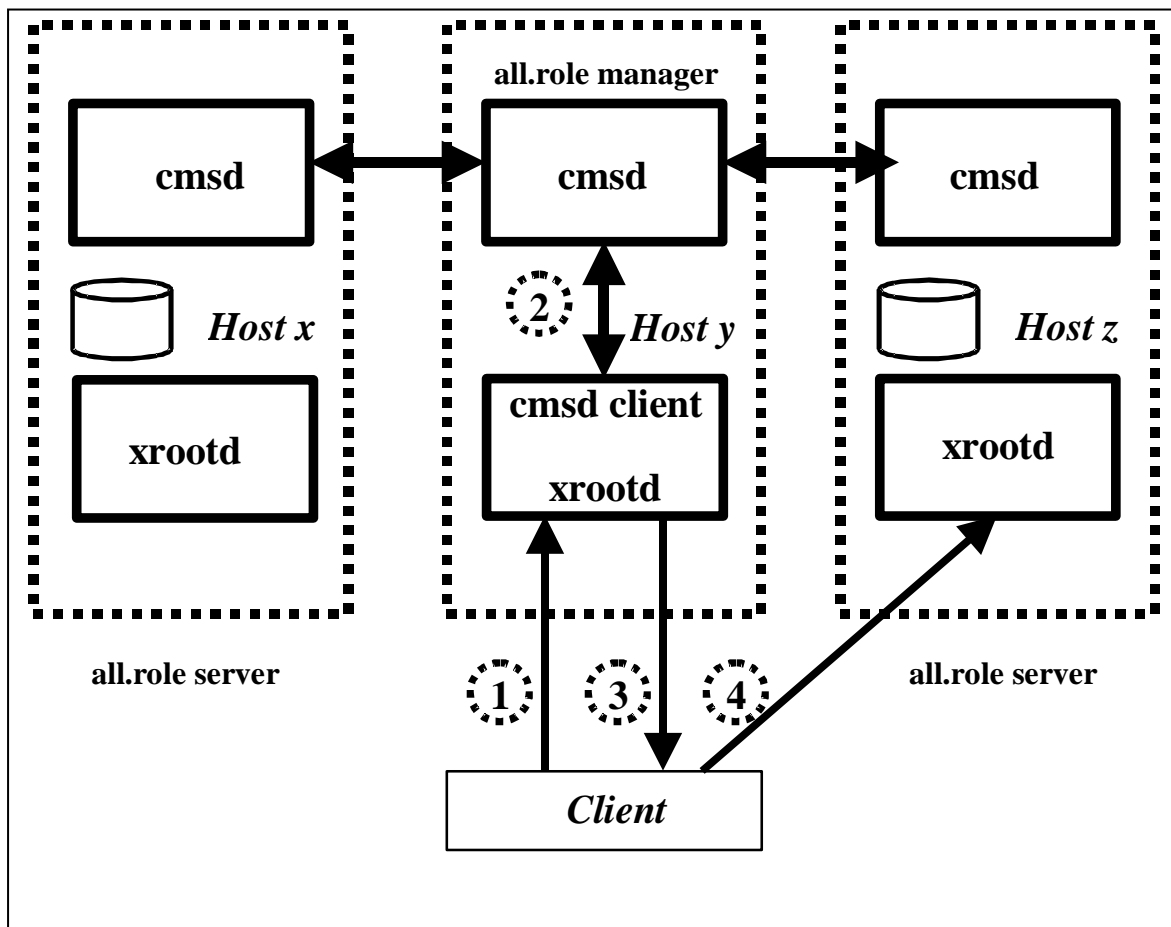

In the diagram, there are three hosts: x , y , and z . Host y serves as the load balancer. Hosts x and z are the hosts that can be used to serve data to clients and load is to be distributed between the two. Consequently, host y runs a manager **cmsd** while hosts x and z run server **cmsd**'s.

The servers connect to the manager and provide load information. The **xrootd** running on host y connects to the manager as well. However, the **xrootd** on host y uses the manager to determine which server to direct client requests. It does not serve any actual data files.

The typical open request is handled in four steps:

1. The client directs the open request to the **xrootd** that runs on the manager's host.
2. The **xrootd** asks the **cmsd** manager which machine is the best to use to process the file. The manager determines the best machine using a variety of configurable parameters.
3. The **xrootd** on host y tells the client, in this example, that host z is the best host to use for the file.
4. The client then redirects the request to the **xrootd** running on host z .

In order to make the system as flexible as possible, the manager **cmsd** does not know how many or which hosts will act as servers. For security purposes, you can restrict hosts based on host name as well as by **NIS** netgroup. Thus, servers essentially subscribe to the manager claiming that they have file resources. During the subscription process, each server indicates the file paths to which it is willing to provide data access. Periodically, the manager **cmsd** requests load information from each server. Each server reports CPU, network I/O, queue, memory, paging load as well as free space. This information is used to select the best available server for an open request.

The decision is tempered whether or not the server already has the file on disk or whether the file must be staged to disk from a Mass Storage System. The manager may decide that all available servers are too loaded and force a file to be replicated on a less loaded server. This provides additional data paths to the file. Replicated load balancing is only compatible with read-only files. The manager can direct client's to a writable version of a file but only on servers that have indicated that they offer write access on the associated path. In general, only one such server may exist for each particular path.

In order to provide a fully redundant service, all servers may be replicated and cross-connected. The following figure shows a full crossbar configuration.

Each server **cmsd** subscribes to two manager **cmsd**'s. Each **xrootd** that can redirect clients subscribes to two managers. Thus, the loss of any single manager **xrootd** does not affect load balancing. More complex arrangements are possible since each server may have any number of managers and each **xrootd** can subscribe to any number of managers.

In order to ease migration, any peripheral (i.e., data server) **xrootd** can always be directly used². This means that load balancing only occurs when a client contacts a redirecting **xrootd**. For systems that are being configured this way for the very first time, you should always use the "**xrd.port any**" directive for data server **xrootd**'s. This allows the **xrootd** to use an arbitrary port number. In this mode it is very difficult for any client to directly use a data server **xrootd** without first contacting the manager **xrootd** first.

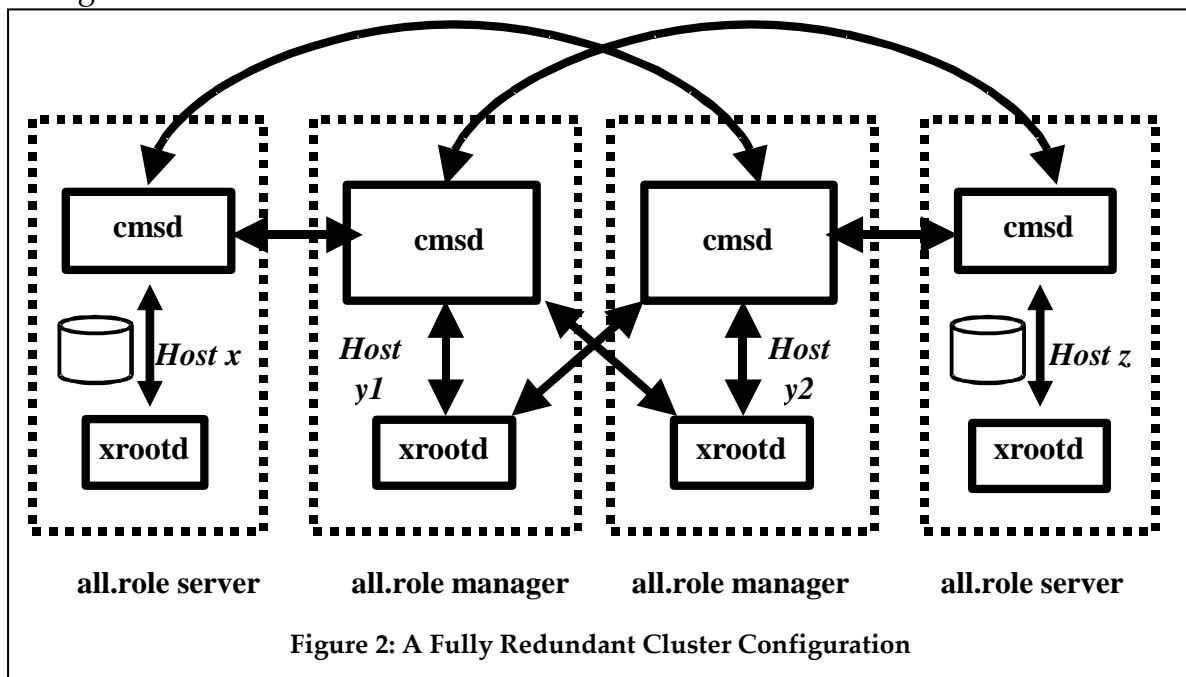

² You make effectively prevent this by using the **-a xrootd** command line option.

1.1 Directives and Components

Clustering consists of four distinct components:

1. The manager **cmsd** process (typically in a separate machine).
2. Supervisor **cmsd** processes (*only* for clusters of more than 64 servers).
3. Server **cmsd** processes, and
4. An integrated **cmsd** client in the **xrootd** process, which can be a manager, supervisor, or server.

A manager **cmsd** always communicates with supervisor and server **cmsd**'s as well as a manager **xrootd**. Server **xrootd**'s only communicate only component with their server **cmsd** counterpart. Two distinct directives are used to identify the participants:

1. **all.role** which tells each component whether it is to function as a manager, supervisor, or server; and
2. **all.manager** that tells each component the DNS name of the manager.

1.1.1 Clusters with 64 or fewer data servers

Use the following general steps to successfully configure a cluster that has 64 or fewer data servers:

- Determine which servers will be used for data serving (i.e., run a data server **cmsd**) and which for redirection (i.e., run a manager **cmsd**). A manager is not capable of also serving data. Use the "**all.role**" directive to differentiate servers and managers.
- Use the **allow** directive to restrict the set of valid data servers.
- Determine the scheduling policy using the **cms.sched** and **cms.space** directives.
- Determine which port number will be used for inter-server communication and specify it for the manager **cmsd** using the *mandatory* **all.manager** directive (see below).
- Remember to specify the **xrootd** port number for the associated manager **xrootd** using the **xrd.port** directive, if the default of 1094 is unacceptable.
- Determine the set of data servers. Unless direct access is important, you should configure data servers with "**xrd.port any**".
- For each data server, determine which file paths it will handle. In general, a number of servers should serve the same path.
- Use the **all.export** directive on each data server to restrict it to its set of paths.
- If a data server will be also creating files, use the **space** directive to indicate which file systems may be used for file creation.

- Use the **all.manager** directive to tell each **xrootd** and **cmsd** the location of its set of managers.
- Start a data server **cmsd** server on each **xrootd** data server machine. For each **xrootd** that will be redirecting, use the **all.role manager** directive to enable redirection mode.³
- Start the manager, server, and **xrootd**. See the **cmsd** command described in the next section. The start-up order is not important.

The following diagram and corresponding configuration file illustrates how to cluster 30 data servers with two managers.

```
# Specify the data server port number. This is only relevant to
# managers, so we qualify the specific port number using the "if".
#
xrd.port any
xrd.port 1094 if man01.u.org man02.u.org

# Using a cmsd requires the enhanced file system. We must specify the
# location of the shared library that implements the file system.
#
xrootd.fslib /opt/xrootd/lib/libXrdOfs.so

# Specify which paths are to be exported (default is r/w)
#
all.export /data

# Tell everyone the role it will have. Use a default of server but
# qualify it depending on hostname using the "if".
#
all.role server
all.role manager if man01.u.org man02.u.org

# Tell everyone the location of each manager.
#
all.manager man01.u.org:1213
all.manager man02.u.org:1213

# Tell the cmsd which machines are allowed to connect
#
cms.allow host man*.u.org
cms.allow host data*.u.org
```

Configuration "myconfig.cf" for a 30 Data Server Cluster

There are additional directives to further tune the system and are described on the following pages.

³ Refer to the "xrootd ofs & oss Configuration Guide" for more information.

1.1.2 Clusters with 65 or more data servers

Configuring a cluster of more than 64 data servers is just slightly more complicated than configuring a smaller cluster. The complication arises from the fact that some additional management servers need to be started. The configuration file, however, is no more complicated. Below are the steps you should take to successfully configure large clusters.

- Choose the port numbers you wish to use for the manager **xrootd** and **cmsd** servers. Typically, **xrootd** uses port 1094 and specified with the **xrd.port** directive. For **cmsd** port 1213 is used and specified with the **all.manager** directive. Other **xrootd** servers should specify "**xrd.port any**".
- Choose the number of manager nodes you wish to run. You must configure at least one manager node. The manager is the first point of contact for a client and is also the cluster leader. A manager should run on a dedicated machine of modest power (e.g., 512MB RAM, 800MHZ clock speed, 100Mb ethernet).

A manager node consists of

- a) an **xrootd** configured with the "**all.role manager**" directive.
- b) a **cmsd** configured with "**all.role manager**" directive.

You may configure more than one manager and run them in either fail-over mode (the default) or in load balancing mode where each manager shares part of the client load (see the **all.manager** directive). Each manager **xrootd-cmsd** pair must run on a separate machine.

- Compute the number of supervisor nodes you need. A supervisor node acts as a local manager for a group of 64 other nodes. These nodes may be data servers or supervisors. A supervisor node consists of
 - a) an **xrootd** configured with the "**all.role supervisor**" directive. Additionally, specify the "**xrd.port any**" directive.
 - b) a **cmsd** configured with the "**all.role supervisor**" directive.

You only need to configure supervisor nodes if you are running more than 64 data servers. The number of supervisor nodes is based on the number of available manager plus supervisor slots. A recursive formula is needed to calculate the minimum number. Since you normally wish to start more than the minimum number of supervisors, a simplified formula can be used.

Conservatively, you will need one supervisor node for each group of 64 data servers. For instance, if you plan to run 500 data servers you will need the upper limit of $500/64$ supervisors (i.e., 8).

Each supervisor node can run on a data server node. If you wish to share resources in this way, choose data server nodes that will be as lightly loaded as possible. The performance requirements for a supervisor node are the same as a manager node.

- Configure the data server nodes. A data server node delivers actual data to clients. It consists of
 - a) an **xrootd** configured with the “**all.role server**” directive. Additionally, specify the “**xrd.port any**” directive.
 - b) a **cmsd** configured with the “**all.role server**” directive.

Configure as many data server nodes as you need. Keep in mind that at least one additional supervisor node is need for each group of 64 data servers.

The performance requirements are determined by the performance needs of clients. The server should have enough disk space, adequate network bandwidth (e.g., Gb ethernet), and significant cpu and i/o resources. If you wish to use memory mapped files, then the node should have a commensurate amount of real memory.

For example, assume you wish to cluster 99 data servers in the way shown below.

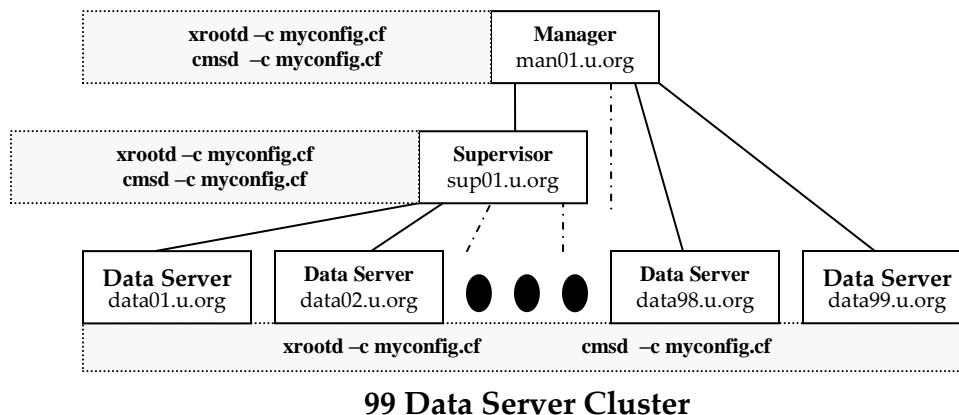

Here we wish to have only one manager. We will need at least one supervisor. While the simplistic formula indicates two supervisors are needed; in practice, the cluster could self-organize by affiliating 63 data servers and one supervisor (a total of 64) with the manager and affiliating the remaining data servers (36) with the supervisor.

With two supervisors, the cluster would affiliate 62 data servers and two supervisors with the manager, and split the remaining data servers across the two supervisors. So, either configuration would work. Fortunately, the cluster attempts to automatically find the best organization given the resources at hand. Configuration files for small and large clusters will differ only slightly from each other. Notable differences involve **allow** and **role** directives. Configuration file simplicity relies on the use of regular names for various hosts.

```
# Specify the data server port number. This is only relevant to
# managers, so we qualify the actual port number using the "if".
#
xrd.port any
xrd.port 1094 if man01.u.org

# Using a cmsd requires the enhanced file system. We must specify the
# location of the shared library that implements the file system.
#
xrootd.fslib /opt/xrootd/lib/libXrdOfs.so

# Specify which paths are to be exported (default is r/w)
#
all.export /data

# Tell the cmsd which machines are allowed to connect
#
cms.allow host man01.u.org
cms.allow host sup01.u.org
cms.allow host data*.u.org

# Indicate the role this server will have based on host name (the
# default role is that of server)
#
all.role server
all.role supervisor if sup01.u.org
all.role manager    if man01.u.org

# Tell everyone the location of the manager.
#
all.manager man01.u.org:1213
```

Configuration "myconfig.cf" for a 99 Data Server Cluster

1.1.3 Frequently asked questions

Does start-up order matter?

Generally, it does not matter in which order nodes are started. For the efficiency minded, starting supervisor nodes ahead of data server nodes allows the system to converge on a stable configuration faster.

How long will it take for the system to converge?

This depends on how many servers are in the configuration. Generally, it takes approximately 1 to 13 seconds for a server to find its correct place in the cluster. However, the process is run in parallel across all of the servers. So, the system should converge in less than 30 seconds for a configuration of about a 1,000 nodes. By default, the system delays full availability for 90 seconds, this should be sufficient time for convergence of even extremely large installations.

What happens if I have too few supervisors?

If there are not enough supervisors relative to the number of data servers, one or more data servers will be orphaned and unavailable. If you suspect this, check the manager's log. It will contain warnings about orphaned data servers.

What happens if I have more supervisor nodes than I need?

Since the system tries to evenly distribute data servers across all available supervisors, excess supervisors are used to further reduce the load on supervisor nodes. The excess supervisors are also used as "hot spares" in the event one of the supervisors becomes unavailable. You should configure as many "extra" supervisors as you feel are necessary to provide a suitable level of fault tolerance.

Can I run all the supervisors on a single node?

Yes, but you will need to assign each **cmsd** a unique instance name using the **-n** option. Additionally, the same **-n** option value must be specified for the **xrootd** that is paired with a particular **cmsd**. Use the "if" directive, keyed off the instance name, to maintain a single configuration file. Finally, each **xrootd**, other than the one tied to the manager **cmsd**, must be started with the "port any" directive to allow for arbitrary port selection. You should realize that running all of the supervisors on a single node creates a large single point of failure.

How do I run a data server and a supervisor on the same node?

Use the provided **StartCMS** and **StartXRD** scripts. For a supervisor **cmsd** and **xrootd**, specify the “**all.role supervisor**”. For a data server **cmsd** and **xrootd** specify the “**all.role server**” directive. You should make sure that “**xrd.port any**” is specified for supervisor and data server **xrootd**'s to prevent any port conflicts

What does the “-port any” xrootd command line option actually do?

The “**-port any**” option allows **xrootd** to choose any port that is available. The selected port number is then forwarded to the **cmsd**. This allows the **cmsd** to redirect clients to the proper port even though it's not known ahead of time. This only works if the **cmsd** is *not* started with the **-i** option (the default) and the **xrootd** is started with the “**all.role server**” (for data servers) or **all.role supervisor**” directive (for supervisors). This does not eliminate the need for starting the manager **cmsd** and its **xrootd** counterpart with well-known ports

Does that mean I can use -port any to run multiple data servers on a single node?

Yes. See the answer to “Can I run all the supervisors on a single node?”

Can I use the -port any option to prohibit clients to bypass the cmsd?

Yes. This is actually recommended. Since arbitrary port numbers are chosen, a client cannot directly connect to a data server without using the manager **xrootd**. However, while significant programming effort is required to capture port numbers at run-time; any “management by obscurity” method can be defeated.

1.2 Created Files

The following files are created by the **cmsd**:

Path	Type	Modified by	Purpose
/tmp/[name]/.olb/olbd	TCP Socket	adminpath and -n option	Local xrootd - server cmsd communications
/tmp/[name]/.olb/olbd.super	TCP Socket	adminpath and -n option	Local xrootd - supervisor cmsd communications
/tmp/[name]/.olb/olbd.notes	UDP Socket	adminpath and -n option	Local cmsd server event notifications
/tmp/[name]/.olb/olbd.seton	UDP Socket	adminpath and -n option	Local cmsd supervisor event notifications
/tmp/[name]/cmsd.pid	File	pidpath and -n option	Holds the process id and the local path prefix (i.e., localroot) for a server cmsd .
/tmp/[name]/cmsd.mangr.pid	File	pidpath and -n option	Holds the process id and the local path prefix (i.e., localroot) for a manager cmsd .
/tmp/[name]/cmsd.superpid	File	pidpath and -n option	Holds the process id and the local path prefix (i.e., localroot) for a supervisor cmsd .
/var/adm/olbd/core/[name]/core	File	-n option	Core file via default in StartXRD.cf
/var/adm/olbd/logs/[name]/cmsdlog	File	-l option and -n option	Log file via default in StartXRD.cf

The **adminpath** directive specifies the directory where the remaining files are written. The **pidpath** directive specifies the directory where the pid file is written. The **-n** option specifies the **cmsd** instance name. If specified, the instance name is automatically suffixed to the **adminpath** and **pidpath**, as shown by “[name/].” A directory is also create in the current working directory for core files and the log file destination is modified by inserting “[name/].” in the destination specified by the **-l** option. If necessary, the directory is created.

1.3 Starting the cmsd Process

Use the following command to start a manager or server **cmsd** process.

```
cmsd [ options ] -c cfn  
  
options: [-l fn][-n name] [esoteric]  
  
esoteric: [-b] [-d] [-i] [-k {num | sz{k|m|g}}] [-p port]  
  
[-s pfn]
```

Function

Start the Cluster Management Services Daemon.

Parameters

-c *cfn* The name of the configuration file. You must specify the name of a configuration file even if it is empty.

Options

-l *fn* Directs error messages and any trace output to the indicated file, *fn*. By default, messages are directed to standard error.

-n *name*

The instance name of the **cmsd**. There is no default. See the notes for more information on this option.

Esoteric Options

-b Runs the program in the background. You should also specify **-l**.

-d Turns on debugging.

-i The **cmsd** subscribes to a manager **cmsd** whether or not the local primary data server contacts the **cmsd**. Also, see the **cms.nowait** directive.

-k *num* | *sz*{**k**|**m**|**g**}

Keeps no more than *num* old log files. If *sz* is specified, the number of log files kept (excluding the current log file) is determined by how much space they use. Hence, kept log files will not exceed *sz* bytes. The *sz* must be suffixed by **k**, **m**, or **g** to indicate kilobytes, megabyte, or gigabytes, respectively.

-p *port*

The TCP port, or service name associated with a port, that the manager **cmsd** is to use for new connections. There is no default. If the port is not specified on the command line, it must be specified using the **all.manger** directive.

-s *pfm* Specifies the name of the file that is to hold the process id upon start-up.

Defaults

None.

Notes

- 1) A configuration file is not optional.
- 2) The same configuration file may be used for manager and server **cmsd**'s. Directives not relevant to a particular mode of operation are ignored.
- 3) The **cmsd** related directives may be placed in the **xrootd** configuration file as well. Thus only one configuration file needs to be maintained per machine.
- 4) If a log file is specified, the file is closed at midnight, renamed to have a date suffix (i.e., *fn.yyyymmdd*) and possible sequence number (i.e. *fn.yyyymmdd.n*), and a new log file is opened. This allows you to write an external time-driven script that rotates **cmsd** log files.
- 5) The order in which servers are started is unimportant.
- 6) You must start at least one **cmsd** in manager mode. The number of supervisor **cmsd**'s is approximately determined by dividing the number of server mode **cmsd**'s by 64 less one.
- 7) In a supervisor role, the **cmsd** acts as both manager and server. Supervisor **cmsd**'s are used to cluster groups of 64 server **cmsd**. Since a supervisor **cmsd** can subscribe to a manager or supervisor **cmsd**, it is possible to cluster together a virtually unlimited number of data servers. During start-up, a **cmsd** writes its process id as well as its local path prefix and administrative path into a file. The location of the file is determined by the **pidpath** directive, as modified by the **-n** option. The name of the file is determined by the **cmsd**'s role (see the **role** directive). Refer to the section "Created Files" for the name used for this file.

Notes on Esoteric Options

- 1) The **-i** option provides for a loose coupling between servers running on the same host. The **cmsd** executes asynchronously from the host's data server and can subscribe to a manager before the data server is available on the host.
- 2) Without **-i**, a host is not available for selection until the host's data server is ready.
- 3) Once the **xrootd** contacts the **cmsd**, the host automatically becomes ineligible for selection whenever the data server becomes unready,
- 4) The **-i** option is meant for to be used with data servers that are unable to communicate with the local **cmsd**. You should *not* specify this option for the **xrootd** server.
- 5) **Warning**: the default **cmsd** mode (i.e., wait for data server) must be used in conjunction with **xrootd**'s configured for clustering; otherwise the host will never be selected by the manager **cmsd**.
- 6) **Warning**: The **-i** option disables port remapping. With port remapping, a client is redirected to the port actually being used by the data server that is the target of the redirection. This allows arbitrary or hidden ports to be used, none of which need be the same. When port remapping is disabled, clients are always redirected to the port they initially used to contact the redirector.
- 7) The **-i** option is automatically implied if you include the **nowait** directive in the configuration file.
- 8) The **-b** option forces the program into the background. If **-l** is not specified; all output messages are discarded.
- 9) The **-b**, **-p**, and **-s** command line options are meant to be used by start-up scripts (e.g. **init.d**).
- 10) **Warning**: Command line options, except for **-s**, over-ride corresponding configuration file directives.

Example

```
cmsd -c /opt/xrootd/cmsd.cf
```

1.3.1 Running multiple cmsd's on the same host

The **cmsd** supports running as many **cmsd**'s as you would like on the same host (i.e., machine). This is accomplished by the `-n` command line option. This option assigns an instance name to the **cmsd**. The **cmsd** uses instance name to maintain a separate disk name space for files that it needs to create.

There is no default instance name; however, the system uses the word **anon** to refer to unnamed **cmsd**'s.

In order to run more than one **cmsd** on the same host, each **cmsd** must be given a unique instance name that is also valid as a directory name. Server and supervisor **cmsd**'s pose no port contention problems since they always use whatever port happens to be free. Manager **cmsd**'s are assigned specific port numbers (see the **manager** directive). Therefore, if you wish to run more than one **cmsd** manager on a host, each manager must also be assigned a unique port number.

The **cmsd**'s always work in pairs with **xrootd**'s. The pairing only works within the same instance. That is, if a **cmsd** with an instance name of **foo** is to be used with a particular **xrootd**; then that **xrootd** must be given an instance name of **foo** as well.

Failure to follow these directions will prevent proper communications from being established between **xrootd**'s and **cmsd**'s.

Notes

- 1) You may run one instance of a supervisor **cmsd** on the same machine as you run a server mode **cmsd**. You may not run manager and supervisor **cmsd**'s on the same machine unless you designate a new instance name (see the `-n` option) for the manager **cmsd**.
- 2) By design, there can only be one logical instance combination of a manager, supervisor, and server running on the same machine. The `-n` option allows you to create new logical instances by assigning each instance a different name. This allows you to run multiple instances of the **cmsd** on the same machine.
- 3) Since the instance name is used to pair **xrootd**'s with their respective **cmsd**'s, specify instance names consistently for **xrootd**'s and **cmsd**'s using the `-n` option on the **xrootd** command line.

1.3.2 Using the StartCMS Script to Start cmsd

The **StartCMS** script may be used to start **cmsd**. The script options and parameters are:

```
StartCMS [-c cfn ] [-D] [-t] [-v] [other]
```

Function

Start an **xrd**-based daemon implementing the **cmsd** protocol.

Options

- c *fn* The name of the configuration file. This overrides the configuration file specified in the **StartXRD.cf** configuration file.
- D Turns on script tracing.
- t Displays commands that will be executed without executing them (i.e., test).
- v Turns on verbose output.
- other* Other **cmsd** command line options to be passed unchanged to **cmsd**.

Notes

- 1) The **StartCMS** script uses a configuration file named **StartXRD.cf** to set default values. Refer to the “Xrd/Xrootd Configuration Reference” on how to specify default values.
- 2) The **StartXRD.cf** file must reside in the same directory as **StartCMS**.
- 3) By default, all required directories must start at the parent directory of where the **StartCMS** script resides. For example, if **StartCMS** resides in “/opt/xrootd/etc” then the executable **cmsd** is assumed to reside in “/opt/xrootd/bin” and the relevant libraries in “/opt/xroot/lib”, and **cmsd** configuration file is assumed to reside “/opt/xrootd/etc”.
- 4) Use the **StopCMS** script to stop **cmsd**.

1.3.3 Using the StopCMS Script to Stop cmsd

The **StopCMS** script may be used to stop **cmsd**. The script options and parameters are:

```
StopCMS [-c] [-D]
```

Function

Stop an **xrd**-based daemon implementing the **cmsd** protocol.

Options

- c** Allows the script to end normally even when **cmsd** was not found to be executing.
- D** Turns on script tracing.

Notes

- 1) The **StopCMS** script tries to stop and process executing “**cmsd**” as well as the **XrdOlbMonPerf** program.
- 2) **StopCMS** does *not* read the **StartXRD.cf**

2 Mandatory Configuration Directives

This section describes directives that are must be specified to configure the Cluster Management Service.

2.1 manager

```
all.manager [ meta | peer | proxy ] [ all | any ]
```

```
host[+]{:port | port} [ if conds ]
```

Function

Specify the manager **cmsd** location.

Parameters

meta Identifies the **cmsd** meta-managers that **cmsd** managers should subscribe to.

peer Identifies the **cmsd** managers that **cmsd** servers with peer roles (i.e., “peer manager” or “peer proxy manager”) should subscribe to.

proxy Identifies the **cmsd** managers that **xrootd** servers with proxy roles (i.e., “proxy” or “proxy server”) should subscribe to.

all Uses a load distribution algorithm to select an appropriate manager. Refer to the usage notes for more information.

any Uses a fail-over algorithm to select an appropriate manager. Refer to the usage notes for more information.

host The DNS name or IP address of the **cmsd** manager. If *host* ends with a plus sign (+), then the all hosts addresses associated with *host* are considered to be available managers.

port The TCP port number or service name at which the manager will accept connections. The port may be specified with an adjacent colon or space separation.

conds The conditions that must exist for this directive to apply. Refer to the description of the **if** directive on how to specify *conds*.

Defaults

None; see the Notes for requirements. If you do not specify **all** or **any**, then **any** is assumed.

Notes

- 1) You must specify the “*manager*” directive for each **xrootd** given a **manager** role and for every **cmsd** given a **server** or **supervisor** role.
- 2) You must specify the “*manager peer*” directive for every **cmsd** given a **peer** or **peer manager** role.
- 3) You must specify “*manager proxy*” directive for each **xrootd** given a **proxy** or **proxy server** role.
- 4) This is a global directive and *must* be qualified by the “**all**” prefix.
- 5) All non-peer manager **cmsd**’s use the *manager* directive to establish a communications channel with each indicated manager.
- 6) You may specify up to 16 different managers.
- 7) For **xrootd** requests, when more than one manager is present, requests can either be distributed among the managers (**all** mode) or sent to a primary manager; with alternates used as backup servers (**any** mode). In either case, should a manager fail, the next available manager is selected.
- 8) If the manager host name ends with a plus, then all the IP addresses associated with host are treated as managers and every non-manager **cmsd** and **xrootd** subscribes to each one. This allows you to easily construct fault-tolerant configurations using the IP address alias feature in DNS.
- 9) The *host* specifies the machine that is running **cmsd** in a manager role.

Example

```
all.manager beastmanager.slac.stanford.edu 1213
```

2.2 role

```
all.role rolename [ if conds ]  
  
rolename: [meta] manager | [peer] [proxy] manager |  
  
           peer | proxy | [proxy] server |  
  
           [proxy] supervisor
```

Function

Designate the role the server is to have.

Parameters

rolename

The server's role in the configuration. See the usage notes and the following section for an explanation of roles.

conds The conditions that must exist for this directive to apply. Refer to the description of the **if** directive on how to specify *conds*.

Defaults

```
all.role manager
```

Notes

- 1) This is a global directive and *must* be qualified by the “**all**” prefix.
- 2) A role of **manager** indicates that the **cmsd** is at the top-most level of the server hierarchy and is used to locate files.
- 3) A role of **server** indicates that **cmsd** is at the bottom-most level of the server hierarchy and is used by pure data servers to serve data files.
- 4) A role of **supervisor** indicates that the **cmsd** is at an intermediate-level of the server hierarchy and is used to bridge the top-most level and the bottom-most level.
- 5) A role of **meta manager** indicates that **cmsd** is to act as a manager and accept subscriptions from other managers. Meta managers allow you to federate administratively independent clusters.
- 6) A role of **peer** indicates that the **cmsd** is not only to act as a **manager** but also is to subscribe to other managers and act as a **peer**.

- 7) A role of **proxy** indicates that the **xrootd** is at the top- *and* bottom-most level of the server hierarchy. When contacted, the **xrootd** acts like a **manager** to locate the target file. However, unlike a true redirector, the **xrootd** actually performs the requested operation as if it were a **server** acting in behalf of the client making the request.
- 8) Any **xrootd**'s designated as proxies may only communicate with **cmsd**'s that have also been designated as proxies. However, **peer proxy** components may communicate with any type of manager **cmsd**.
- 9) The following table describes the effect each role has on an **xrootd** server and its corresponding **cmsd** server.

Example

```
all.role supervisor if sup*.slac.stanford.edu
```

2.2.1 Role Summary Table

Role	cmsd	xrootd
manager	Provides a search service across one or more "server" or "supervisor" cmsd 's.	Logs into one or more cmsd 's, identified by the "manager" directive, and provides a redirection service
server	Subscribes to a "manager" cmsd , identified by the "manager" directive, in order to form a cluster <i>and</i> accepts logins from a local xrootd .	Logs into a local "server" cmsd and provides data from a locally accessible file system.
supervisor	Same as "server" <i>plus</i> provides a search service across one or more server or supervisor cmsd 's.	Logs into a local "supervisor" cmsd and provides a redirection service.
meta manager	Provides a search service across one or more "manager" cmsd 's.	Logs into one or more meta manager cmsd 's, identified by the "manager meta" directive, and provides a redirection service

Role	cmsd	xrootd
proxy	<i>Not supported.</i> This role is only meant to designate stand-alone xrootd proxy servers.	Logs into one or more cmsd 's, identified by the "manager proxy" directive, <i>and</i> provides data from servers identified by the manager cmsd .
proxy manager	Same as "manager" <i>but</i> only accepts cmsd 's and xrootd 's that have a "proxy" role (i.e., can only manage proxies).	Same as manager role <i>except</i> that the manager cmsd 's must also have a proxy role.
proxy server	Same as "server" <i>except</i> that managers and the local xrootd must also have a proxy role.	Same as "proxy" <i>and</i> logs into a local "proxy server" cmsd to be part of a cluster.
proxy supervisor	Same as "supervisor" <i>but</i> only allows proxy cmsd subscriptions (i.e., can only manage proxies).	Logs into a local "proxy supervisor" cmsd and provides a redirection service.
peer	Same as peer manager <i>but</i> neither needs nor allows any cmsd subscribers.	Same as manager role.
peer manager	Same as manager role <i>plus</i> subscribes to other manager cmsd 's, identified by the "manager peer" directive, as an alternate.	Same as manager role.
peer proxy manager	Same as "peer manager" <i>but</i> only allows proxy cmsd subscriptions (i.e., can only manage proxies).	Same as manager role <i>except</i> that the manager cmsd 's must also have a proxy role.

3 Common Configuration Directives

3.1 adminpath

```
all.adminpath path [ group ]
```

Function

Designate the path used for administrative communications.

Parameters

path is the path to use for Unix named sockets.

group

Allows group access to *path*.

Defaults (see warning in the notes)

The default administrative path is `"/tmp/olb"`.

Notes

- 1) **Warning:** if idle `/tmp` directories and socket files are automatically deleted by the system, you should specify a different stable path; otherwise, the system may become unresponsive. Normally, `"/var/run/cmsd"` is used.
- 2) Unless **group** is specified, only the user running **cmsd** can write to the named sockets. This is done to ensure that non-privileged users cannot send **cmsd** administrative requests.
- 3) The server, manager, and supervisor **cmsd**'s create stream sockets named `"olbd.admin"`, `"olbd.nimda"`, and `"olbd.super"` in this directory, respectively. These sockets are used for administrative communications.
- 4) The server and manager **cmsd**'s respectively create datagram socket named `"olbd.notes"` and `"olbd.seton"` in this directory. These sockets are used for external notifications.
- 5) The **adminpath** is modified by the `-n` command line option.

Example

```
all.adminpath /var/run/cmsd
```

3.2 allow

```
cms.allow { host | netgroup } name
```

Function

Restrict the hosts that can subscribe to the manager **cmsd**.

Parameters

host *name*

The DNS host name allowed to subscribe to the **cmsd**. Substitute for *name* a host name. The host name may contain a single asterisk anywhere in the name. This lets you allow a range of hosts should the names follow a regular pattern.

netgroup *name*

The **NIS** netgroup allowed to subscribe to the **cmsd**. Substitute for *name* a valid **NIS** netgroup. Only hosts that are members of the specified netgroup are allowed to subscribe to the **cmsd**.

Defaults

None. If **allow** is not specified, any host is allowed to subscribe.

Notes

- 1) This directive is only used by manager-mode **cmsd**'s.
- 2) You may specify any number of hosts and netgroups. Any host matching a specified name or is a member of a specified netgroup is allowed to subscribe to the **cmsd**.
- 3) **Warning!** Using hostname based security relies on the security of the DNS server and the inability of other hosts spoofing and successfully using the "allowed" IP addresses. The two security assumptions have severe limitations.
- 4) Use strong authentication to provide a more robust security framework. Refer to the **seclib** directive for more information.

Example

```
cms.allow host kandata*.slac.stanford.edu
```

3.3 defaults (an oss directive)

```

oss.defaults options

options: [no]check [no]compchk [no]dread

           {forcero | readonly | r/o | r/w | [not]writable}

           {inplace | outplace} {local | global | globalro}

           {[no]mig | [not]migratable} [no]mkeep [no]mlock

           [no]mmap [no]rcreate [no]ssdec [no]stage

```

Function

Specify default file processing options.

Parameters⁴

Option	Disabled/Enabled Function	Default
forcero	Convert all file open requests to read-only access (cmsd & oss).	writable
local	Do not export this path via the cluster manager (cmsd only).	global
global	Export this path via the cluster manager (cmsd only)	global
globalro	Export this path via the cluster manager as read-only (cmsd only).	global
readonly r/o	Files may only be opened for read access (cmsd & oss).	writable
r/w	Path is writable (cmsd & oss)	writable
[no]stage	[Do not] stage a file from a remote storage system should it not exist in the local file system at open time.	nostage
[not]writable	Path is [not] writable (cmsd & oss).	writable

⁴ Only **cmsd**-related options are shown in the table. Other options are specific to **xrootd** or the **oss** component. Consult **xrootd** and **ofs/oss** references for details on unlisted options.

Notes

- 1) This directive is identical to the **oss.defaults** directive and establishes the defaults for the **export** directive. This allows you to keep a single configuration file for **cms** and **oss** components.
- 2) Directive options may be applied to selected paths using the **export** directive. This allows you to selectively over-ride the default,
- 3) The **defaults** directive *should* be specified prior to any **export** directives.

Notes on **forcero** and **readonly**

- 1) The **forcero** and **readonly** options declare any files prefixed by the path to be non-writable. The **cmsd** excludes all servers declaring the prefix as non-writable when looking for a file that is to be modified or created.
- 2) The **mlock**, **mkeep**, and **mmap** options cause a path to have the **forcero** attribute.

Notes on **local**, **global**, and **globalro**

- 1) The **local** option prevents the applicable paths to be seen by the manager **cmsd**; making them globally inaccessible via the redirector.
- 2) The **global** option makes a path eligible to be used by the manager **cmsd** and associated redirector. This is the default.
- 3) The **globalro** option makes a path eligible to be used by the manager **cmsd** and associated redirector in **readonly** mode; regardless of how it is actually declared for the server. This allows you to export local **writable** paths as global **readonly** paths.

Notes on **[no]stage**

- 1) When **stage** is in effect, files are dynamically staged from a remote storage system to local file space when opened, if the file is not already locally on disk. The **cmsd** selects servers that can stage the file should no other server have the file or if otherwise eligible servers are overloaded or unavailable.
- 2) When **nostage** is in effect, the server claims that the files must exist on disk in order to be accessed.
- 3) The **nostage** and **stage** directives may be applied to selected paths using the **path** directive.

Example

```
oss.defaults stage forcero
```

3.4 dfs

```

cms.dfs [limit [central] [=] rate]
          [lookup {central | distrib}] [mdhold mdtm]
          [qmax qmax] [redirect {immed | verify}]

```

Function

Configure distributed file system handling.

Parameters

limit Establish limits on meta-manager requests. The limit is applied in the manager node when **central** is specified. Otherwise, the limit is applied where file systems look-ups occur (see **lookup**). The *rate* specifies the number of look-ups per second allowed. When *rate* is preceded by an equals sign (=), look-ups are metered to occur exactly at the specified *rate*. Otherwise, the system uses a median-average algorithm. See the notes on how these algorithms differ. By default, no limit is applied and is equivalent to specifying zero or a value greater than 1000 for *rate*.

lookup

Specifies where file existence checks are to be performed. By default, they are performed in data server nodes (i.e. **distrib**). If the manager node has access to the distributed file system, file existence can be checked by the manager if **central** is specified. See the notes on the pros and cons of using **central** vs. **distrib** look-ups.

mdhold

Instructs data servers to keep track of missing directories for *mdtm* time. The *mdtm* may be suffixed by **s** (the default), **m**, or **h** to indicate seconds, minutes, and hours, respectively. When a look-up for a non-existent file occurs, the data server automatically looks-up its parent directory and records whether or not it exists. If the directory does not exist, the fact is remembered for *mdtm*. Otherwise, the fact that the directory exists is remembered for *mdtm**10. Subsequent look-ups for files in missing directories will immediately fail. See the notes on appropriate values. The default is zero which turns this optimization off.

qmax Specifies the maximum number of look-ups that can be queued for processing. When *qmax* is reached, the oldest unprocessed look-ups are deleted and no look-up is performed; effectively returning a “file does not exist” response. The *qmax* is ignored if no rate limit applies. The minimum value is 1. The default value is $\text{rate} \times 2.5$. See the notes on how this interacts with rate.

redirect

Specifies how the manager is to handle file look-ups by clients. When **immed** is specified, no look-up is performed and the client is immediately directed to most suitable data server where the client re-drives the look-up. This is the default for proxy managers. When **verify** is specified, the manager first determines whether or not the file exists (either locally or via a server query, as specified by **lookup**) and if the file exists, the client is directed to a suitable server. This is the default for non-proxy managers. See the usage notes on how this option affects performance.

Defaults

Proxy manager:

```
cms.dfs limit 0 lookup distrib mdhold 0 redirect immed
```

Otherwise:

```
cms.dfs limit 0 lookup distrib mdhold 0 redirect verify
```

Notes

- 1) When you specify the **dfs** directive, the **cmsd** optimizes file processing to avoid duplicate requests for the file. A distributed file system is essentially a shared-everything system and if one data server has access to a file, all data servers have access to the same file. Examples of distributed file systems are: **dCache**, **GPFS**, **HDFS**, **Lustre**; and **xrootd** when the front-end by a proxy server.
- 2) By default, the **cmsd** assumes a shared-nothing system where each data server has its own independent file system. In order to determine who has a file, all data servers are necessarily interrogated.
- 3) As in shared-nothing systems, the **cmsd** still honors the exported paths declared by servers in a shared-everything system. So, while each server has access to all of the file system you may logically restrict access by exporting different paths from each server.

- 4) The **limit** parameter only applies to meta-manager requests and provides you the option of limiting the impact of external queries. If the **limit** is set too low or is set much higher than the ability of the underlying file system to handle look-ups (i.e., `stat()`), files will appear to be non-existent to the meta-manager at the queried node.
- 5) When **limit** is specified, the default is to use a median-average algorithm to limit look-ups. This algorithm allows for brief bursts of activity before applying deterministic pacing. This kind of algorithm is much more responsive and requires less CPU time. However, it can subject the underlying file system with up to 50% of the allowed look-ups in a very brief period of time. The alternative is to pace the look-ups at a deterministic rate. While this is not as responsive and requires more CPU time, it guarantees a predictable file system load.
- 6) The **limit rate** is directly affected by the **lookup** parameter. When look-ups are done by managers (i.e., **lookup central**) the actual rate is equal to the specified value times the number of managers configured to talk to a meta-manager. When look-ups are done by data servers (i.e., **lookup distrib**, the default) the actual rate is equal to the specified value times the number of data servers whose manager talks to a meta-manager. In either case, the number of meta-managers does not affect the rate.
- 7) In general, it is rare that a limit needs to be specified and is normally not recommended.
- 8) The **lookup** parameter controls where file look-ups occur. The default is to spread look-ups across all of the data servers. This greatly increases scalability at the cost of increased latency. If the look-up request rate is relatively low or the underlying file system can process a look-up in less than a few milliseconds, then specifying **central** can reduce the latency while maintaining reasonable scalability. The underlying distributed file system must be available to the manager when central look-ups are enabled. The choice of look-up impacts the specified **limit**, if any.
- 9) The **mdhold** parameter allows you to reduce the overhead when looking up missing files when look-ups are done for files in a missing directory. The **mdhold** parameter control how long the **cmsd** is to remember that a directory is missing. Future look-ups in a missing directory immediately fail without actually checking the underlying file system during this time. Since the **cmsd** has no way of knowing if a directory was actually created during this time, the hold time should be set to a small value and should not be specified at all if directories are actively created for files likely to be looked up either by the meta-manager or the manager. Excessively long hold values will likely result in files being incorrectly tagged as missing.

- 10) The **mdhold** processing occurs where look-ups are preformed (see the **lookup** parameter). The **limit** parameter does not apply to directory look-up requests.
- 11) The **qmax** parameter controls the maximum number of outstanding look-up requests. It is only meaningful when a limit is in effect. Look-up queues may occur when the limit is set too low or when the actual file system look-up rate is lower than the specified limit. When the queue limit is reached, the oldest requests are discarded resulting and the file is deemed missing for those look-up requests.
- 12) The **redirect** parameter can also be used to optimize look-ups. In **immed** mode (the default for proxy managers), the manager immediately redirects clients to a suitable data server without any file look-up at all. The server is responsible for doing the look-up. In **verify** mode (the default for non-proxy managers), the manager performs the look-up to ensure that a selected data server will in fact be able to process the client's request. The choice of mode should be done in the context of how clients reach a manager node. If most of the activity is local to the cluster then **verify** mode is usually better. If most of the activity is generated by meta-manager redirects then **immed** mode is usually better.

Example

```
cms.dfs lookup central mdhold 1m
```

3.5 export

```
all.export  path [ xoptions ] [ options ]
```

Function

Specify processing options for any path matching the specified path prefix.

Parameters

path The path prefix to which the specified options apply. If no options are specified, the current defaults are used.

xoptions

xrootd options to apply to any path whose prefix matches *path*. See the **export** directive described in the **xrd/xrootd** configuration reference.

options

oss and **cmsd**-specific (i.e., **local**, **global**, and **globalro**) options to apply to any path whose prefix matches *path*. Refer to the **oss.defaults** directive for a detailed explanation of these options.

Defaults

All paths are processed according to the default options in effect at the time the path directive is encountered. Defaults are set using the **defaults** directive.

Notes

- 13) Any number of **export** directives may be specified. They are cumulative and are checked in decreasing length order (i.e., most-specific to least specific).
- 14) The **export** directive is usually defined when configuring **xrootd** and the **oss** component. Additional **cmsd**-specific options may also be included.
- 15) The **export** directive is used by **xrootd** and **cmsd** to determine which paths are valid for incoming client requests.
- 16) The **export** directive is used by **oss** component to enforce desired processing attributes.

Example

```
all.export /xrd/files/staged mig nodread rcreate
```

3.6 **localroot** (an oss directive)

```
oss.localroot path
```

Function

Specifies where the local file system name space is actually rooted.

Parameters

path The path to be pre-pended to any local path specified by a client request.

Defaults

None. Paths are used locally as specified.

Notes

- 1) The **localroot** parameter allows you to keep the external namespace consistent even when you move the associated file system from one location to another. Say that a file system is mounted at **/xrd**. This means that all file paths start with **/xrd**. If now you needed to mount the file system at **/usr/xrd** then by specifying

```
oss.localroot /usr
```

the external view of the file system would remain the same since **oss** will automatically prefix all paths with **/usr** and use the new mount point.
- 2) The **cmsd** honors the **oss localroot** directive. This allows you to use a single configuration file for the **cms** and **oss** components.

Example

```
oss.localroot /usr
```

3.7 perf

```
cms.perf parms  
parms:    [ int time ] [ pgm prog ]
```

Function

Specify how load is computed and reported.

Parameters

int *time*

The estimated *time* between load reports as computed by *prog*. The time may be suffixed by **s** (the default), **m**, or **h** to indicate seconds, minutes, and hours, respectively.

pgm *prog*

The program that computes the machine load and write the information to standard out. The **pgm** parameter must be the last parameter on the line.

Defaults

```
cms.perf int 3m.
```

Notes

- 1) This directive is only used by server-mode **cmsd**'s.
- 2) There is no default value for the program and load information cannot be collected and reported unless a load collector exists. A sample program, **cms_MonPerf**, is supplied for this purpose. This program uses the **rperf** command, among others, to calculate the cpu, i/o, and various other load levels.
- 3) The specified program is started by the server-mode **cmsd** at startup time. It is automatically restarted after two failures to report a load within the specified interval.

- 4) The specified program must write 5 white-space separated numbers to standard out. The last number must be terminated by a new-line character (“\n”). Each number must be normalized to 100, with 0 indicating no load and 100 indicating saturation. The numbers are in the order:
1. system load
 2. cpu utilization
 3. memory utilization
 4. paging load, and
 5. network utilization.

Example

```
cms.perf int 5m pgm /usr/etc/ooss/olb_MonPerf 300
```

3.8 prep

```
cms.prep [echo] [reset cnt] [scrub time] [ifpgm ifprog]
```

Function

Specify how offline file preparation is done.

Parameters

echo Writes to the log all of the files found in the external in-preparation queue whenever a reset occurs.

reset *cnt*

The maximum number of scrubs of the in-preparation queue that can be done before the contents of the queue are recomputed. The default is three (3).

scrub *time*

The *time* between scrubs of the in-preparation queue. The *time* may be suffixed by **s** (the default), **m**, or **h** to indicate seconds, minutes, and hours, respectively. The default is 20 minutes.

ifpgm *ifprog*

If specified, *ifprog* replaces the default built-in prepare mechanism and becomes the interface that adds, removes, and lists preparation queue files. The following section describes the input, output, and calling conventions that *ifprog* must have. The **ifpgm** parameter must be the last parameter on the line. Any parameters after *ifprog* are passed to the program via the argument list. Quoted values must be avoided as they are not correctly passed.

Defaults

None. Preparation queue handling is normally disabled.

Notes

- 1) This directive is only used by server- and manager-mode **cmsd**'s.
- 2) The default prepare mechanism relies on the File Residency Manager's **frm_xfragment**. You must configure and run **frm_xfrd** to successfully implement the default prepare mechanism.

- 3) Each **cmsd** that can stage files is also capable of preparing files to be online prior to their active use. This is done through the prepare protocol. The mechanism that is actually used to bring files to local disk is the responsibility of the external infrastructure.
- 4) The **prep** directive *enables* and, optionally, describes the interface to that infrastructure. If you do not specify the *prep* directive, even with no arguments, file preparation is disabled.

Example

```
cms.prep scrub 10m ifpgm /opt/xrd/bin/prep_mgr
```

3.8.1 Optional Prepare Interface Program Requirements

Most installations chose the default mechanism to route file preparation requests. This employs the File Residency Manager along with `frm_afragment` and `frm_xfrd`. Refer to the File Residency Manager Reference for full details. If you have special needs, you can over-ride the built-in default by specifying an `ifprog` (see previous section). The requirements of this program are:

- 1) The `ifprog` is used to add, remove, and list preparation queue files. When specified, it is started at initialization time and is expected to run continuously, and is automatically restarted should it fail. Parameters are sent via standard in, one request for each new line terminated record. Except for the “list” (i.e., `?`) request, the program should not write any output to standard out. Output to standard error is included in the `cmsd` log file.
- 2) When the `cmsd` needs to know the exact contents of the preparation queue (e.g., files waiting to be brought to local disk) it sends a single question. Refer to the default prepare query message for the exact response requirements.
- 3) The format of the messages sent to the program is described under the `prepmmsg` directive. To the prepare query message description for the required response.
- 4) If prepare notification is requested, the command should adhere to the following message format:

```
Successful:   ready      requestid msg path
Unsuccessful: unprep    requested msg path
```

requestid is the request identifier associated with the completed request.

msg is the text that followed the notification url (see the `prepmmsg` directive). This text must be sent without inspection.

path is the *logical* name of the file that successfully prepared or whose preparation failed.

- 5) Because file preparation is done on a best-effort philosophy, the preparation program is free to honor (or not) the requests in any way. Currently, the `cmsd` does not check the return status of the program nor expects any error output (e.g., messages).

3.8.1.1 Default Prepare Request Message (prepmmsg)

The default⁵ message that is sent to the **prep ifpgm**'s stdin when a prepare operation is required has the following format:

```
+[traceid] requestid npath prty mode path [path [ . . . ]]
```

Where:

- traceid* The unauthenticated identifier associated with the client making the request. The *traceid* is automatically included when communicating with the File Residency Manager (frm).
- requestid* The request identifier that can be used to group this request into a unique set of requests. The *requestid* is globally unique.
- npath* The notification path to be used to indicate how the request complete. This field may contain:
- no notification is to be sent.
 - file:///path send *msg* via local named pipe named *path*
 - mailto://user send e-mail to *user*
 - tcp://rhost:port/msg send *msg* via tcp to rhost:port
 - udp://rhost:port/msg send *msg* via udp to rhost:port
- prty* The request priority: 0, the lowest, to 2, the highest.
- mode* The processing mode and may contain a combination of the following letters:
- f** send fail notice (not affected by q flag)
 - n** send success notice
 - q** suppress default failure notice (i.e., quiet)
 - r** file is expected to be only read
 - w** allow the file to be modified
- path* The absolute *logical* name of the file to be prepared. If more than one path is specified, each path is separated by a blank.

⁵ This message may be specified by using the **stagemsg** directive.

Notes

- 1) You can change the format of a prepare request message with the `prepmg` directive. However, you cannot use the supplied `frm_pstga` and `mps_prep`⁶ commands unless you use the default format.

3.8.1.2 The Prepare Cancel Message

The following message is sent to the `prep ifpgm`'s stdin to cancel a stage operation:

```
- requestid
```

Where:

requestid The request identifier used in a previous prepare request. All entries with this *requestid* should be removed.

Notes

- 2) You cannot change the format of a prepare cancel request message.

3.8.1.3 The Prepare Query Message

The following message is sent to the `prep ifpgm`'s stdin to cancel a stage operation:

```
?
```

Notes

- 1) The *ifprog* should respond with a list of new-line separated absolute paths associated with queued requests.
- 2) You cannot change the format of a prepare query request message.

⁶ `mps_prep` along with `mps_PreStage` and `mps_Stage` are deprecated. The `frm_xfrd` should be used instead.

3.9 sched

```
cms.sched parms  
parms: [ cpu pcpu ] [ io pio ] [ mem pmem ] [ pag ppag ]  
        [ runq prunq ] [ space putl ] [ fuzz fnum ]  
        [ gsdflt gsdp ] [ gshr gsp ] [ maxload mload ]  
        [ refreset sec ]
```

Function

Specify the parameters for the load balancing scheduling algorithm.

Parameters

cpu *tcpu*

The percentage of cpu load to be used to compute the overall load of a server.

fuzz *fnum*

The percentage difference two overall load values must have before they are considered different. A value of 100 suppresses the use of load in any scheduling decisions.

gsdflt *gsdp*

The default share the meta-manager should use in the absence of a manager-specific value. The default is 100. See the notes for more information.

gshr *gsp*

The maximum percentage of meta-manager requests that should be directed to this manager (i.e. the global share). The default is 100. See the notes for more information.

io *pio* The percentage of io load to be used to compute the overall load of a server.

maxload *mload*

The maximum overall load a server may have. Servers whose overall load is greater than *mload* are not scheduled.

mem *tmem*

The percentage of memory load to be used to compute the overall load of a server.

pag *tpag*

The percentage of paging load to be used to compute the overall load of a server.

refreset *sec*

The number of seconds between server reference count resets.

runq *trunq*

The percentage of runq load to be used to compute the overall load of a server.

space *putil*

The percentage of space utilization to be used to compute the overall load of a server when selecting a server to stage or create a file.

Defaults

```
cms.sched cpu 0 io 0 mem 0 pag 0 runq 0 space 0 fuzz 20 gshr 100 refreset 3600
```

Notes

- 1) This directive is only used by **cmsd**'s with manager and supervisor roles.
- 2) The load-balancing algorithm chooses from all available servers the server whose computed overall load is smallest. When two servers have the same load, as determined by **fuzz**, the least selected server is chosen.
- 3) Other factors apply in selecting a server. For instance, whether or not the server has the requested file on disk, whether the server is allowed to dynamically stage a file, whether the server has sufficient disk space, etc.
- 4) The sum of *pctcpu*, *pctoi*, *pctmem*, *pctpag*, and *pctrunq* should be equal to 100.
- 5) If the sum of *pctcpu*, *pctoi*, *pctmem*, *pctpag*, and *pctrunq* is equal to zero, or if **fuzz** is 100, servers are selected strictly round-robin.
- 6) Round-robin scheduling is also forced when performance monitoring is disabled (see the **ping usage** directive).

- 7) Server selection, with or without load information, is accomplished by using an internal reference counter in order to equalize the selection process. Since this counter may drift due to external anomalies encountered during scheduling, it is periodically reset. The **refreset** parameter controls the minimal reset frequency. However, the counter is only reset if sufficient selection activity occurred.
- 8) The **gshr** option allows you to set the maximum relative share of requests that a meta-manager subscriber wishes to accept from a meta-manager. Since the percentage is relative its effect is determined by the relative shares of other subscribers to the meta-manager. For instance, if all subscribers indicate the same share then this is equivalent to a share of 100 from the perspective of any individual subscriber. Hence, for global shares to be useful requires some amount of co-ordination between participating subscribers.
- 9) The global share is used by the meta-manager to select a subscriber only when a choice of subscribers exists (i.e., more than one subscriber has a requested file). In such a case, the meta-manager selects a subscriber so as not to exceed any individual subscriber's relative share of requests.
- 10) A subscriber's share may be temporarily reduced if the subscriber is repeatedly selected because it is the only one which has a requested file.
- 11) The **gsdflt** option allows you to specify a default share (e.g. 50). This allows you to treat most subscribers the same and only differentiate those that are exceptions by giving them higher or lower shares than the normal default share.
- 12) The **gshr** and **gsdflt** options only apply to interactions with a meta-manager.

Example

```
cms.sched cpu 50 io 50
```

3.10 seclib

```

cms.seclib path
or
all.seclib path

```

Function

Specify the location of the security interface layer.

Parameters

path The absolute path to the shared library that contains an implementation of the Security (sec) interface that **cmsd** is to use for strong authentication.

Defaults

Strong authentication is disabled unless **seclib** is specified.

Notes

- 1) The **sec** interface allows you to provide an arbitrary authentication implementation (e.g., Kerberos, GSI, etc).
- 2) A **sec** implementation requires that compatible interface libraries be used on the server and client sides of the connection.
- 3) Refer to **XrdSecEntity.hh** and **XrdSecInterface.hh** for guideline on how to write a **sec** interface.
- 4) If you are using a common configuration file for all components (e.g., **xrootd** and **cmsd**) with security enabled; consider the following points.
 - a. If the *same* security library is used for **xrootd** and **cmsd**, specify **all.seclib** to avoid having to specify the **seclib** directive twice.
 - b. If a different set of protocols is being used for **xrootd** vs. **cmsd**, bracket the differences with an “if exec” construct. For instance,

```

if exec cmsd
  security directives for cmsd
else
  security directives for xrootd
fi

```

Example

```

cms.seclib /opt/xrootd/lib/libXrdSec.so

```

3.11 space

```
cms.space [linger num] [recalc sec]
          [[min] [min%] min[k|m|g|t] [[hwm%] hwm[k|m|g|t]]]
```

Function

Specify how servers are selected for file creation.

Parameters

linger *num*

The number of times a server may be reselected without an intervening server being selected for allocation. The default is zero (0).

recalc *sec*

The number of seconds between free space recalculations.

min% The minimum amount of free space, as a percentage of the largest partition, a server must have in order for it to be selected. If the percentage is less than the *min* byte value, the *min* value is used.

min The minimum amount of free space a server must have in order for it to be selected. You may suffix the byte quantity by **k**, **m**, **g**, or **t** to indicate kilobyte, megabytes, gigabytes, or terabytes, respectively.

hwm% The minimum amount of free space, as a percentage of the largest partition, a server must have in order for it to be selected after free space has fallen below *min*. If the percentage is less than the *hwm* byte value, the *hwm* value is used.

hwm The minimum amount of free space a server must have in order for it to be selected after free space has fallen below *min*. You may suffix the byte quantity by **k**, **m**, **g**, or **t** to indicate kilobyte, megabytes, gigabytes, or terabytes, respectively.

Defaults

```
cms.space linger 0 recalc 15 min 2% 10g 5% 11g
```

Notes

- 1) This directive is only used by manager-and server mode **cmsd**'s.
- 2) The **space** values are used during server selection when either a file is opened in create mode or when a file must be dynamically staged.

Example

```
cms.space min 2g 10g
```

3.12 **space** (an oss directive)

```
oss.space group { path | ppfx* }
```

Function

Specify the location of one or more disk partitions.

Parameters

group The arbitrary name for the disk partition. Specify a 1- to 63-character name. While the name is required, the **cmsd** does not use it for any purpose.

path The absolute path at which the disk partition is mounted.

*ppfx** All directory entries that start with *ppfx* in the containing directory are to be used as disk partitions.

Defaults

None.

Notes

- 1) This directive is identical to the **oss.space** and, now deprecated, **oss.cache** directives. This allows you to keep a single configuration file for **cms** and **oss** components.
- 2) In order to redirect staging operations and file creations, the manager **cmsd** must know how much space is available on each server.
- 3) If the **xrootd** server is running a partitioned file system (i.e., files are allocated via symbolic links to one of many possible file system partitions) then specify each file system partition.
- 4) The path may end in an asterisk, indicating that all entries in the parent directory that start with the specified prefix are to be used as a file system partition. This is useful when partition mount points have regular names (e.g., /data/space01, /data/space02, etc.).
- 5) If the **cmsd** does not find any **space** directives, it infers the file systems to be used using the **export** directive.

Example

```
oss.space public /xrootd/space01
```

4 Esoteric Configuration Directives

This section describes directives that are normally not specified. You may wish to review these directives to be familiar with additional configuration options that are available.

4.1 `conwait`

```
cms.conwait sec
```

Function

Set the number of second to delay an **xrootd** client in the absence of a manager **cmsd**.

Parameters

sec The number of seconds that a client is delayed when there is no connection to a manager **cmsd**.

Defaults

```
cms.conwait 10
```

Notes

- 1) When a client attempts to locate a file and no connection exists to a manager **cmsd** process, **xrootd** defers the client for **conwait** seconds. After the time period expires, the client automatically retries the request.
- 2) The time period chosen for **conwait** should be sufficiently long to establish a connection to a **cmsd**.

Example

```
cms.conwait 6
```

4.2 delay

```
cms.delay parms  
  
parms:  [discard num] [drop sec] [full {sec | *}]  
  
         [hold msec] [lookup sec] [overload {sec | *}]  
  
         [peer sec] [qdl sec] [qdn num] [servers num[%]]  
  
         [service sec] [startup sec] [suspend sec]
```

Function

Manage processing latency.

Parameters

discard *num*

The maximum number of times a message can be forwarded before it gets discarded.

drop *sec*

The number of seconds a malfunctioning server is allowed to stay in the configuration before it gets dropped. The delay allows time for a server recover before clients are sent to other functioning servers. Clients are delayed during the recovery window.

full *sec*

The number of seconds to delay a client when no eligible servers have sufficient space to place a file. By default, delays due to insufficient disk space are not allowed and when the condition occurs, the client is given an **ENOSPC** error condition. You may decide that this is a recoverable condition and are willing to let clients wait until disk space becomes available. Specifying an asterisk uses a dynamically computed optimal value (see the notes).

hold *msec*

The number of milliseconds to optimistically hold a file query request waiting for a server to reply that the file is available. Should a server reply within this window, the client is immediately redirected to that server, subject to the **qdn** value.

lookup *sec*

The number of seconds to delay a client when trying to determine which servers have the requested file on disk.

overload *sec*

The number of seconds to delay a client when all available servers are overloaded. Specifying an asterisk uses a dynamically computed optimal value (see the notes).

peer *sec*

The maximum number of seconds to delay a client when resources are not available in the immediate cluster in the presence of a peer manager. Should any individual wait time exceed *sec*, the client is redirected to an appropriate peer manager.

qdl *sec*

The number of seconds by which a query must complete (i.e. **query deadline**) with a positive response; after which the file is deemed to not exist. By default, the **qdl** is set to be the same as the **lookup** value.

qdn *num*

The minimum number of servers that must have the file in order to redirect the client within the **hold** period. The default is 1 which causes an immediate redirection when a server indicates it has the requested file (i.e. the fastest responder wins). Values greater than 64 are set to 64.

servers *num*[%]

The minimum number of servers that must be subscribed for load balancing to be effective. The number may be suffixed with a percent sign. When specified this way, the number of available servers must be no less than the specified percentage of the maximum number of servers ever subscribed to the **cmsd** manager since startup. This option effectively determines the server quorum necessary for the **cmsd** to redirect clients.

service *sec*

The number of seconds to delay a client when fewer than *num* servers are subscribed.

startup *sec*

The number of seconds to delay enabling manager service when initially started. This time period allows for servers to subscribe while client requests are delayed. Clients are delayed “**service**” seconds during this time.

suspend *sec*

The number of seconds to delay a client when a selected server is in suspend state.

Defaults

```
cms.delay discard 7 drop 10m full 0 hold 178 lookup 5 overload * peer 0
cms.delay qdl 5 qdn 1 servers 80% service 15 startup 90 suspend 30
```

Notes

- 1) This directive is only used by manager-mode **cmsd**'s.
- 2) Clients do not time out when a delay is imposed.
- 3) When specified, the **qdl** value should be greater than or equal to the **lookup** value.
- 4) The **overload** delay is imposed when all eligible servers have a load greater than the one specified **maxload** on the **sched** directive.
- 5) The **full** and **load** options allow you to specify an asterisk to choose the optimal delay value. The optimal value is computed as

$$\text{ping.ptime} * \text{ping.pcnt} + 30$$
 The value is optimal because the load balancer will see no change in external conditions until this amount of time has gone by. See the **ping** directive for additional details.
- 6) **Warning:** The 80% default for **servers** works better as more servers join the configuration since more servers can fail before the system enters a holding pattern. For sites with less than 6 servers, you should specify a fixed number.
- 7) When the system enters a holding pattern, also known as safe-mode, clients are delayed until the conditions causing the situation are removed. For example, when the number of servers falls below the quorum established by the **servers** option, safe-mode is entered. The system remains in safe-mode until a quorum is re-established.

Example

```
cms.delay lookup 3 full *
```

4.3 fxhold

```
cms.fxhold time[m | h | s]
```

Function

Set the time file existence information is to be cached in memory.

Parameters

time The number of seconds file existence information may be cached. The time may be suffixed by **m**, **h**, or **s** (the default) to indicate minutes, hours, or seconds, respectively.

Defaults

```
cms.fxhold 8h
```

Notes

- 1) This directive is only used by manager-mode **cmsd**'s.
- 2) A manager **cmsd** keeps track of where files are at each server-mode site. To prevent information from getting very stale, it is discarded after the time specified by the **fxhold** directive.
- 3) Setting the cache time too low will substantially increase overhead.

Example

```
cms.fxhold 3h
```

4.4 fsxeq

```
cms.fsxeq { func } xpath  
func: chmod | mkdir | mkpath | mv | rm | rmdir | trunc
```

Function

Designate the program to handle file meta-data operations.

Parameters

func One or more of the indicated functions (i.e., **chmod**, **mkdir**, **mkpath**, **mv**, **rm**, **rmdir**, and **trunc**) that are to be handled by *xpath*.

xpath The absolute path to an executable file. The file will be invoked whenever the **cmsd** is asked to execute one of list functions. Parameters specified after *xpath* are passed to the program via the argument list. Quoted parameters should not be specified as these are not correctly passed.

Defaults

None. The **cmsd** will either use the native operating system call or the local **xrootd** server to perform the functions.

Notes

- 1) This directive is only used by server-mode **cmsd**'s.
- 2) Any number of **fsxeq** directives may be specified in order to map different programs to different functions.
- 3) The **fsxeq** directive is meant to be used in those situations where additional processing needs to occur when one of the indicated functions is executed (e.g., a file needs to be deleted from online disk as well as a Mass Storage System).
- 4) The **cmsd** is asked to execute functions only if the **ofs.forward** directive has been specified for the redirecting file server (e.g., **xrootd**). Refer to the **ofs** configuration manual for more information.

- 5) Each function invokes *xpath* as follows:

Function	Command Invocation
chmod	<i>xpath mode path</i>
mkdir	<i>xpath mode path</i>
mkpath	<i>xpath mode path</i>
mv	<i>xpath oldpath_newpath</i>
rm	<i>xpath path</i>
rmdir	<i>xpath path</i>
trunc	<i>xpath size path</i>

- 6) The executable function must return a status code of zero upon success. Upon failure, the status code should map to the appropriate `<errno.h>` code that describes the failure.

Example

```
cms.fsxeq mv rm /usr/local/bin/fs_cmds -c /opt/fs/fs.cf
```

4.5 **namelib** (an oss directive)

```
oss.namelib path [parms]
```

Function

Specify the location of the file name mapping layer.

Parameters

path The absolute path to the shared library that contains an implementation of the **Name2Name** interface that **cmsd** is to use to make logical file names to physical name for file system specific operations (e.g., open, close, read, write, rename, etc).

parms Optional parameters to be passed to the **Name2Name** object creation function.

Defaults

A built-in minimal implementation driven via the **localroot** and **remoteroot** directives is used.

Notes

- 1) The **Name2Name** interface is defined in `XrdOucName2Name.hh` include file. Refer to this file on how to create a custom file name mapping algorithm.
- 2) The **Name2Name** interface is also used by the **oss** component of `xrootd`.
- 3) The **cmsd** honors the **oss namelib** directive. This allows you to use a single configuration file for the **cms** and **oss** components.

Example

```
oss.namelib /opt/xrootd/lib/libN2N.so
```

4.6 `nowait`

```
cms.nowait
```

Function

Specify that the **cmsd** should not wait for the data server.

Defaults

None, you must specify the **nowait** directive or start the **cmsd** with **-i** to not wait for a data server.

Notes

- 1) The **nowait** directive provides for a loose coupling between servers running on the same host. The **cmsd** executes asynchronously from the host's data server and can subscribe to a manager before the data server is available on the host.
- 2) Without **nowait**, a host is not available for selection until the host's data server is ready.
- 3) Once the **xrootd** contacts the **cmsd**, the host automatically becomes ineligible for selection whenever the data server becomes unready.
- 4) The **nowait** option is meant for to be used with data servers that are unable to communicate with the local **cmsd**. You should *not* specify this option for the **xrootd** server.
- 5) **Warning:** the default **cmsd** mode (i.e., wait for data server) must be used in conjunction with **xrootd**'s **-t** option; otherwise the host will never be selected by the manager **cmsd**.
- 6) **Warning:** The **nowait** directive disables port remapping. With port remapping, a client is redirected to the port actually being used by the data server that is the target of the redirection. This allows arbitrary or hidden ports to be used, none of which need be the same. When port remapping is disabled, clients are always redirected to the port they initially used to contact the redirector.
- 7) The **nowait** directive is automatically implied if you start the **cmsd** with the **-i** option.

Example

```
cms.nowait
```

4.7 **osslib** (an ofs directive)

```
ofs.osslib path [parms]
```

Function

Specify the location of the storage system interface layer.

Parameters

path The absolute path to the shared library that contains an implementation of the storage system interface that **ofs** is to use for storage access for file system specific operations (e.g., open, close, read, write, rename, etc).

parms Optional parameters to be passed to the storage system object creation function.

Defaults

A full-featured built-in implementation is enabled for use by the **cmsd**.

Notes

- 1) The storage system interface is defined in the **XrdOss.hh** include file. Refer to this file on how to create a custom storage system implementation.
- 2) A **cmsd** can automatically become a proxy for another manager **cmsd** if the **osslib** implements a proxy mechanism. If you decide to run a proxy **cmsd** then it and its **xrootd** counterpart should be configured with a role of server.

Example

```
ofs.osslib /opt/xrootd/lib/libmyOss.so
```

4.8 pidpath

```
all.pidpath path
```

Function

Specify the location of the pid file.

Parameters

path The path to be used to create the file where the daemon's process id and local prefix are stored.

Defaults

The process id file is written into **/tmp**.

Notes

- 1) The name of the pid file is determined by the **cmsd**'s role and the **-n** option.
- 2) If the **cmsd** cannot create the pid file because either one already exists but is not owned by the **cmsd**, or the directory permissions prohibit the **cmsd** from creating new file; initialization fails and the **cmsd** exits.
- 3) To create a specific **pidpath** exception for the **cmsd**. Use the "**cms**" prefix instead of "**all**".

Example

```
cms.pidpath /var/run/cmsd
```

4.9 ping

```
cms.ping ptime [ log ucnt ] [ usage pcnt ]
```

Function

Control the keep-alive and load reporting frequency.

Parameters

ptime The time between keep-alive requests sent to each server **cmsd**. The time may be suffixed by **s** (the default), **m**, or **h** to indicate seconds, minutes, and hours, respectively.

log *ucnt*

The number of usage requests that must be made before the reported usage is logged. A value of 0 suppresses any logging of usage information.

usage *pcnt*

The number of pings that must occur before usage is requested from a server **cmsd**. A value of 0 suppresses usage requests.

Defaults

```
cms.ping 60 log 10 usage 10
```

Notes

- 1) This directive is only used by manager-mode **cmsd**'s.
- 2) Unspecified values in subsequent ping directives default to the last known value.
- 3) Smaller *ptime* values will discover a failing **cmsd** in a smaller time window at increasing overhead.
- 4) Smaller *pcnt* values will ask for usage information averaged across a smaller time-window.
- 5) Usage information will be requested every *pcnt*ptime* seconds, assuming *ptime* is in seconds. Select a *pcnt/ptime* value that averages usage across a reasonable time window for your load (e.g., 5 to 10 minutes).

- 6) Usage information for each **cmsd** server will be logged every $ucnt*pcnt*ptime$ seconds, assuming $ptime$ is in seconds. Choose any value appropriate to your logging needs. For instance, 1 logs usage every time it is requested while 0, the default, does not log usage.
- 7) When $pcnt$ or $ptime$ is set to zero, usage based load balancing is disabled. This means that requests are scheduled round-robin.
- 8) In the subsequent example, keep-alive pings occur every 30 seconds. Usage is requested every five minutes and never logged.

Example

```
cms.ping 30 log 0 usage 10
```

4.10 prepmsg

```

cms.prepmsg msgline

msgline: [text] [var] [msgline]

var:      $CGI | $LFN | $PFN | $RFN | $NOTIFY | $OFLAG |
           $PRTY | $RID | eVar

```

Function

Specify the message to be sent to a piping **prep ifpgm** when a prepare request is received.

Parameters

text Arbitrary text.

var A variable whose value is determined by the current request setting. The following variables may be specified:

\$CGI	all of the opaque information specified after the question mark in the file path
\$LFN	logical file name
\$PFN	physical file name as modified by localroot or the namelib plug-in
\$RFN	remote file name as modified by remoteroot or the namelib plug-in
\$NOTIFY	notification string; as follows:
-	no notification is to be sent.
<i>file://path</i>	send an ofs event message via a Unix pipe named path
mailto://user	send e-mail to <i>user</i>
<i>tcp://rhost:port/msg</i>	send <i>msg</i> via tcp to rhost:port
<i>udp://rhost:port/msg</i>	send <i>msg</i> via udp to rhost:port
\$OFLAG	a character sequence describing the file open processing flags:
w - O_WRONLY O_RDWR	r - O_RDONLY
\$PRTY	request priority
\$RID	request identifier

\$eVar any variable that has been passed along with the file name as opaque information

Defaults

+ \$RID \$NOTIFY \$PRTY \$OFLAG \$LFN

Notes

- 1) Variables must begin with a \$ (dollar sign) and end with a non-alpha-numeric character.
- 2) To include a dollar sign into the message, escape it with a back slash (“\”).
- 3) A backslash escape is only recognized when followed by a dollar sign.
- 4) Important! The **prepmsg** *msgline* is *not* subject to general **set** variable substitution.
- 5) Except for **\$CGI**, the implicit value of a variable that has not been set is the variable name itself, including the dollar sign.
- 6) For **\$CGI**, if no opaque information is found, the variable is substituted with the null string.
- 7) The default **prepmsg** slightly differs from the one given above in that **\$OFLAG** contains additional information. See the description of *mode* under the **prepare** directive for additional information.

Example

```
cms.prepmsg prepare $LFN $PFN $RFN
```

4.11 **remoteroot** (an oss directive)

```
oss.remoteroot path
```

Function

Specifies where the local file system name space is actually rooted in the remote Mass Storage System.

Parameters

path The path to be pre-pended to any path sent to the Mass Storage System for processing.

Defaults

None. Paths are sent to the Mass Storage System as specified.

Notes

- 1) The **remoteroot** parameter allows you to place the online file namespace in a different location within the Mass Storage System. Say that the online file system is mounted at **/xrd**. This means that all file paths start **/xrd**. If you specified

```
oss.remoteroot /usr
```

then the file namespace would be rooted at **/usr/xrd** within the Mass Storage system because all paths would be prefixed by **/usr** before being sent to the Mass Storage System for processing.

- 4) The **cmsd** honors the **oss remoteroot** directive. This allows you to use a single configuration file for the **cms** and **oss** components.

Example

```
oss.remoteroot /usr
```

4.12 repstats

```
cms.repstats [-]option [ [-]option ] [• • •]  
option: all | frq | shr
```

Function

Enable additional statistical reporting.

Parameters

soption

The additional statistics to be reported when **xrd.report** specifies protocol summary reporting. One or more options may be specified. The specifications are cumulative and processed left to right. Each option may be optionally prefixed by a minus sign to turn off the setting. Valid options are:

all	all possible additional information
frq	information about the fast response queue
shr	share usage

Defaults

```
cms.repstats -all.
```

Notes

- 1) See the **xrd.report** directive in the Xrd/Xrootd reference on how to turn on protocol summary reporting.
- 2) When protocol summary information is turned on, the **cmsd** reports basic information that is usually sufficient for monitoring purposes. The **repstats** directive allows you to request additional information that may be useful for tuning purposes.
- 3) The **frq** information is only available for **cmsd**'s with a manager or supervisory role.
- 4) The **shr** information is only available for meta-manager **cmsd**'s.
- 5) The Monitoring Reference on more information about the reported statistics.

Example

```
cms.repstats shr
```

4.13 request

```
cms.request [delay secd] [fwdwait msf] [noresp num]  
           [prepwait mss] [repwait secr]
```

Function

Specify request timing parameters.

Parameters

secd The number of seconds to delay an **xrootd** client when the **cmsd** has not responded in *secr* seconds to a request to locate the file the client wishes to access.

msf The number of milliseconds of wait time to impose between forwarded requests (i.e. mv, rmdir, and rm).

num The number of consecutive *secr* **cmsd** response timeouts that may be tolerated before **xrootd** attempts to find another working **cmsd** manager.

mss The number of milliseconds of wait time to impose between prepare requests.

secr The number of seconds to wait for a **cmsd** response.

Defaults

```
cms.request delay 5 fwdwait 0 noresp 4 prepwait 33 repwait 3
```

Notes

- 1) When a client attempts to locate a file a request is sent to the **cmsd** to locate the best possible copy of the file. Should the **cmsd** not respond in *secr* seconds, **xrootd** defers the client for *secd* seconds. After the time period expires, the client automatically retries the request.

Example

```
cms.request delay 3 repwait 1
```

4.14 trace

```

cms.trace [-]toption [ [-]toption ] [• • •]
toption: all | debug | defer | forward | redirect |
         stage

```

Function

Enable tracing.

Parameters

toption

The tracing level. One or more options may be specified. The specifications are cumulative and processed left to right. Each option may be optionally prefixed by a minus sign to turn off the setting. Valid options are:

all	selects all possible trace levels except debug
debug	traces internal functions in cmsd and the xrootd cmsd client
defer	traces imposed wait responses in cmsd
forward	traces forwarded functions in the xrootd cmsd client
redirect	traces request redirection in the xrootd cmsd client
stage	traces binding of locate requests to servers to have promised to stage in files in cmsd .

Defaults

```
cms.trace -all.
```

Notes

6) The **cmsd -d** command line option is equivalent to **cms.trace all**.

Example

```
cms.trace debug
```

4.15 `xmilib`

```
cms.xmilib path [parms]
```

Function

Specify the location of the external manager interface layer.

Parameters

path The absolute path to the shared library that contains an implementation of the External Management Interface that `cmsd` is to use to locate file and perform meta-data operations on file names (e.g., mv, rm, etc.).

parms Optional parameters to be passed to the **XMI** object creation function.

Defaults

A built-in implementation based on distributed co-operating `cmsd`'s is used.

Notes

- 1) The **XMI** interface is defined in `XrdOlbXmi.hh` include file. Refer to this file on how to create a custom external manager.

Example

```
cms.xmilib /opt/xrootd/lib/libXMIDPM.so
```

5 The Composite Cluster Name Space

The name space (i.e., directories and file names) in a **Scalla** cluster is, by default, distributed. That means that each data server in the cluster is responsible for maintaining its portion of the name space. Typically, the name space is non-exclusively distributed across all of the data servers. Thus no single server actually knows the complete name space. Indeed, the redirector does not even know the complete name space since it is only concerned about the portion of the name space that is actually active.

In many instances, the lack of a centralized name space is not an impediment because the users of the data access system (i.e., **Scalla**) typically maintain a separate database containing a list of all files in the system along with extended meta-data about each file. So, duplicating some portion of this information in the **Scalla** cluster is unnecessary and inefficient. This directory and file listings are done against the external database as they would be onerous to do using native **Scalla** interfaces.

However, in some instances the proper use of add-on software requires that a centralized full name space exist as this software makes frequent references to portions of the name space. Examples of such systems include **FUSE** (File System in User Space), and the **SRM** (Storage Resource Manager).

5.1 Establishing a Composite Name Space

Scalla allows you to establish a centralized, possibly replicated, composite name space which is the union of the name spaces of all the data servers in the cluster. You do this by configuring additional components that are included as part of the software package. This section describes the steps that you need to take to configure these software components. To better understand the effects of the configuration options you may wish to understand how the name space is actually maintained.

On the top of the following diagram we have a redirector, **R**, and two data servers: **A** and **B**, configured to act as a clustered data access system (i.e., each has an **xrootd** and a **cmsd** process). The bottom portion of the diagram shows how that configuration must change in order to maintain a composite name space. Notice that at the bottom we have added an **XrdCnsd** process to each data server and another instance of an **xrootd** process to the redirector. This additional **xrootd** process does

not participate in the cluster but is merely used to maintain a composite name space on the redirector's local file system.

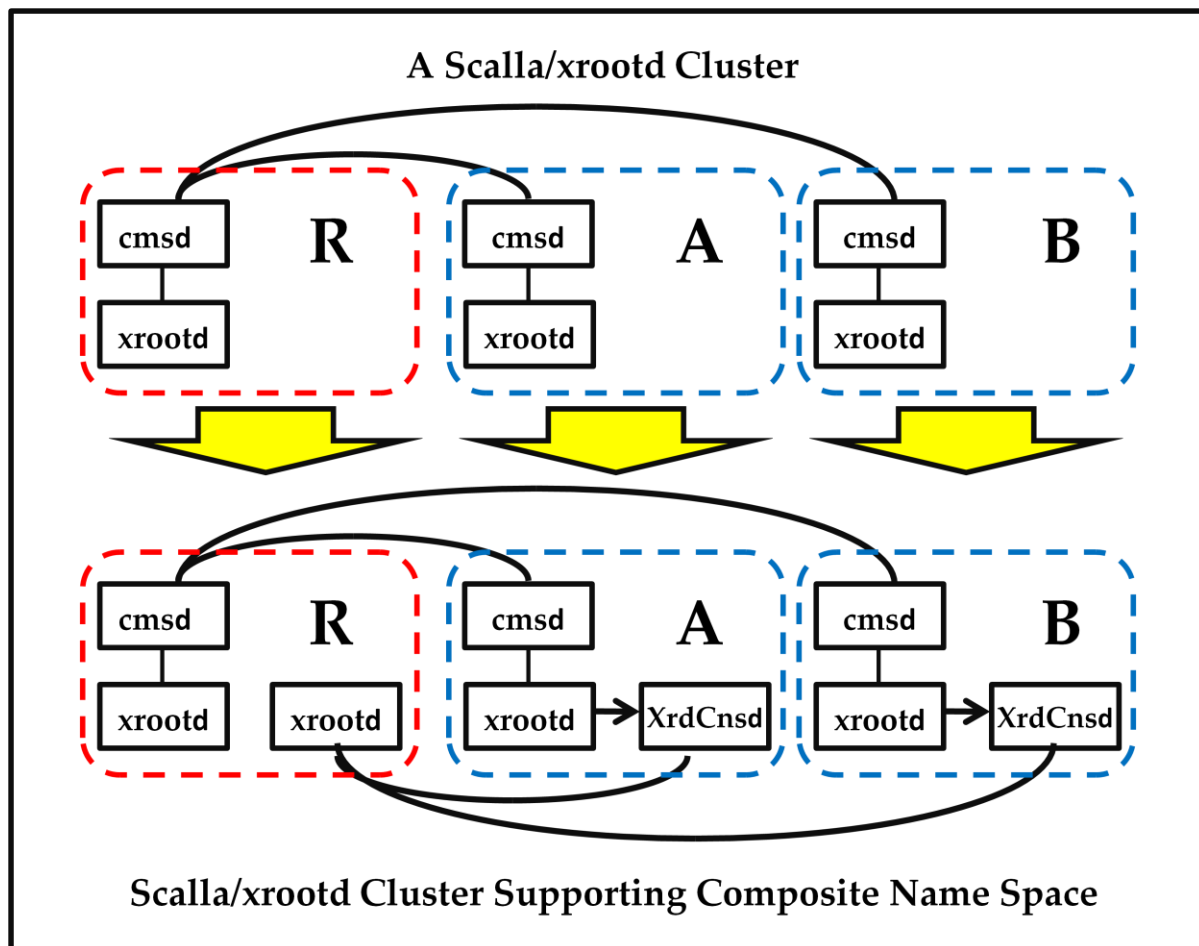

In the bottom of above diagram, each data server **xrootd** sends name space events (e.g., mv or rm) to a program called **XrdCnsd** running as a separate process. The process captures these events and repeats them in the redirector's local file system using the new instance of the **xrootd** process. This mechanism is used to create a composite name space as all data servers re-create their local name space on the redirector's machine. A client using the redirector to list the name space will list the complete name space without the need of contacting each data server.

Several additional options need to be specified in the common configuration file and start-up script to accomplish the following tasks:

1. The new instance of the **xrootd** on the redirector must be given a port number that does not conflict with the standard **xrootd**.
2. Each **xrootd** on the data servers must be told to send name space events (i.e., close, create, mkdir, mv, rm, and rmdir) to the **XrdCnsd** process which the **xrootd** will automatically start.

3. If you choose a non-standard port number (i.e., something other than 1095) in step 1, then you must tell the **XrdCnsd** the port number that you chose so that it can contact the new instance of the **xrootd** running on redirector.
4. In the start-up script, the new instance of the **xrootd** on the redirector must be given a unique instance name using the **-n** option on the **xrootd** command line (e.g., "**xrootd -n cns ...**").

Below is the configuration file that describes a cluster corresponding to the top portion of the previous picture.

```
all.manager R:1094
if R
all.role manager
else
all.role server
fi
```

Several additions to the previous configuration file describe the bottom portion of the previous picture (i.e., the Composite Name Space example). Text in red signifies additions that need to be made.

```
all.manager R:1094
if R && named cns
xrd.port 1095
else if R
all.role manager
ofs.forward 3way R:1095 mv rm rmdir trunc
else
all.role server
ofs.notify closew create mkdir mv rm rmdir trunc \
    | /opt/xrootd/bin/XrdCnsd
ofs.notifymsg create $TID create $FMODE $LFN?$CGI
ofs.notifymsg closew $TID closew $LFN $FSIZE
fi
```

The previous configuration files are minimal and should be considered pedagogical in nature. Additionally, there are many other ways to accomplish the same effect. In any case, your site will likely have a much more descriptive configuration file.

5.1.1 Frequently asked questions

What happens if I kill the XrdCnsd?

It will be automatically restarted by the **xrootd**. If it cannot be restarted, name space events will be lost and the composite name space will diverge from the real name space. You can recreate the name space if you maintain a server inventory (see the next section).

I lost the redirector's file system. How do I get the composite name space back?

If you maintain a server inventory you need not do anything. The composite name space will be automatically recreated. Otherwise, run the **XrdCnsd** program as a command on each data server as follows:

```
XrdCnsd -R -p 1095 redir
```

Where, *redir* is the redirector's host name (assuming that you are using port 1095 for the special **xrootd**).

What do I need to do if I later add another redirector?

You have three options:

1. Bring up the new configuration (you must restart all of the **xrootd** data servers so they notice the new redirector). Tar the existing name space on the old redirector and untar it into the new redirector's file system where the composite name space is being maintained.
2. Use the procedure to restore an existing redirector's name space. For *redir* specify the new redirectors host name.
3. Configure the system to maintain a server inventory. When you bring up the new redirector and restart the **xrootd** data servers, the composite name space will automatically be created in the new redirectors file system.

How do I make sure there are no entries in the composite name space that don't exist on any of the data servers?

Phantom entries are unlikely if you specified the **ofs.forward** directive in the redirector's section of configuration file. However, to address this issue you will need to maintain a server inventory and use the **cns_ssi** command to list discrepancies between all of the server inventories and the composite name space. The truly missing files can then be easily removed with a script. Refer to the **cns_ssi** command for more information.

5.2 Maintaining a Simple Server Inventory

The **XrdCnsd** is capable of maintain a simple server inventory. You may wish to have an inventory for each data server to help you restore files that were on that server after a catastrophic failure. You can also use the inventory to audit the composite name space to make sure it's correct.

By default, no server inventory is maintained. You can add the **-b** option when configuring the cluster to the **XrdCnsd** program (see the **ofs.notify** directive below). The **-b** option tells **XrdCnsd** where to place the inventory on each redirector in the cluster. For instance,

```
ofs.notify closew create mkdir mv rm rmdir trunc \  
|/opt/xrootd/bin/XrdCnsd -b /altas/inventory
```

places the inventory files in the logical directory `"/altas/inventory"` on each redirector. If you have two redirectors, R1 and R2, and you want the inventory on only one of them, prefix the **-b** path with the host name where the inventory is to be placed (e.g., `"-b R1:/altas/inventory"`). As this is a general option, you can place the inventory on any host running an **xrootd** server. Refer to the **XrdCnsd** program description in this reference for additional information.

Inventory files are not automatically updated. This is to significantly reduce overhead. Instead, each server writes log files in its inventory directory (i.e., where the inventory file resides) that detail the changes that need to occur to bring the inventory file up-to-date. Use the **cns_ssi updt** command to apply the log files to the inventory file.

Use the **cns_ssi list** command to list one or more inventory files. The command tells you if there are outstanding log files that should be applied. Refer to the **cns_ssi list** command description in this reference for additional information.

Use the **cns_ssi diff** command to list differences between the composite name space and the set of inventory files created by each data server.

If you remove the inventory file, it is automatically rebuilt.

5.3 XrdCnsd Program

Use the following command as part of the **ofs.notify** directive in the **xrootd** configuration file to start a server **XrdCnsd** process.

```
XrdCnsd [ options ] [redir[:port]] [. . .]

options:  [{-b | -B} [bhost[:bport]:]bpath] [-l lpath]
           [-p port] [esoteric] [cmdline]

esoteric: [-a apath] [-c cfile] [-d]
           [-D dlvl] [-e epath] [-I iint] [-i lint]
           [-k {num | sz{k|m|g}]}] [-q qlim]

cmdline: [-L lclroot] [-N '\n2nlib [parms]' ] -R xpaths
```

Function

Start the Cluster Name Space Daemon.

Parameters

redir[:port]

is the redirector where the cluster name space is maintained. Specify the *port* number of the **xrootd** server that is used to maintain the name space if it differs from the default, 1095, or the port specify with the **-p** option. If you do not specify a redirector, the redirectors configured for the **xrootd** that starts **XrdCnsd** are used.

Options

-b [*bhost[:bport]:*]*bpath*

specifies the path on the remote host where the server's file inventory is to be maintained. The *bpath* is always qualified by "**cns/shost**" where *shost* is the DNS name of **XrdCnsd**'s host machine. Normally, the inventory is maintained on each *redir*. If you wish the inventory to be maintained on a particular machine, specify the machine's host name as *bhost*. If the port of the **xrootd** server used to maintain the inventory differs from 1095 or the port

number specified with **-p**, specify *bport*, the actual port number. When **-b** is not specified, a file inventory is not created.

-B [*bhost[:bport]:*]*bpath*

Works identically to the **-b** option except that it prohibits the maintenance of the composite name space on each *redir*. Use this option is you wish to maintain simple server inventory files but do not want to maintain the full composite name space.

-l *lpath*

directs error messages and any trace output to a file, **cnslog**, places in the directory specified by *lpath*. the indicated file, *fn*. By default, messages are written to standard error unless **XrdCnsd** is started by an **xrootd**. In which case, *lpath* defaults to the ones used by the underlying **xrootd**.

-p *port* is the port number to use wherever a port number may be optionally specified (i.e., *redir* parameter and **-b** option). The default is 1095.

Esoteric Options

-a *apath*

the administrative path where log files, temporary inventory files, and other special files are to be placed. The path is always qualified with “**cns**”. The default is **/tmp** unless **XrdCnsd** is started by an **xrootd**. In which case, *apath* defaults to the one used by the underlying **xrootd**.

-c *cfile* the configuration file to be used for initialization. If *cfile* is not specified, it defaults to the one used by the underlying **xrootd**. Be aware that **-R** implies there is no underlying **xrootd**; making **-c** a mandatory option.

-d turns on server-oriented debugging. By default, debugging is off.

-D *dlvl*

Turns on client-oriented debugging. The *dlvl* is a number from 0 through 4. The higher the number the more detailed the debugging. By default, debugging is off.

-e *epath*

the event path where the event named socket is to be placed. The path is always qualified with “**cns**”. The default is *apath* (see **-a**).

- I *iint*** the time interval between checks for the existence of an inventory file at each location where such a file is to be maintained. Specify a number suffixed by **h**, **m**, or **s** for **hours**, **minutes**, or **seconds** (the default). By default, the interval is eight hours (**8h**).
- i *lint*** the maximum amount of time that may go by before the event log file that tracks name space changes may remain open. Once this interval goes by and the log file has at least one entry, the log file is closed and backed up at the location specified by the **-b** option. Specify a number suffixed by **h**, **m**, or **s** for **hours**, **minutes**, or **seconds** (the default). By default, the interval is twenty minutes (**20m**).
- k *num* | sz{k|m|g}**
keeps no more than *num* old log files. If *sz* is specified, the number of log files kept (excluding the current log file) is determined by how much space they use. Hence, kept log files will not exceed *sz* bytes. The *sz* must be suffixed by **k**, **m**, or **g** to indicate **kilobytes**, **megabyte**, or **gigabytes**, respectively.
- q *qlim***
The maximum number of event log entries that may be written to the log file. Once this number of events has been written, the log file is closed and backed up at the location specified by the **-b** option. Specify a number from 1 to 1024, inclusive. The default is 512.

Cmdline Options

- L *lclroot***
the local root path (i.e., where all logical paths are physically rooted). Normally, this comes from the **oss.localroot** directive processed by the underlying **xrootd**. There is no underlying **xrootd** when you execute **XrdCnsd** as a command. Therefore, if a local root has been specified in the configuration file, it must be specified on the command line.
- N '*n2nlib* [*parms*]**
the name-to-name plug-in library to be used. The *n2nlib*, and optional parameters, normally, come from the **oss.namelib** directive processed by the underlying **xrootd**. There is no underlying **xrootd** when you execute **XrdCnsd** as a command. Therefore, if a name library has been specified in the configuration file, it must be specified on the command line.

-R *xpaths*

runs the program as a command and tries to recreate the name space on each specified *redir*. You must specify at least one *redir* and the exported paths, *xpaths*. Normally, the list of exported paths comes from the **all.export** directive processed by the underlying **xrootd**. There is no underlying **xrootd** when you execute **XrdCnsd** as a command. This is the reason why you must specify the exported paths on the command line. If more than one path is exported, separate each path with a colon. Finally, you may optionally create an inventory file by specifying the **-b** option.

Defaults

```
XrdCnsd -a xrootd -I 8h -I 20m -l xrootd -p 1025 -q 512 xrootd7
```

Notes

- 1) **XrdCnsd** is normally started with the **ofs.notify** directive in the **xrootd** configuration file.

Example

```
ofs.notify . . . |XrdCnsd -b /atlas/inventory
```

5.3.1 Created Files

The following files are created by the **XrdCnsd**:

Path	Type	Purpose
<i>apath</i> /[<i>name</i> ⁸ /]cns/ XrdCnsd.events	FIFO	Local host - XrdCnsd communications.
<i>rhost</i> : <i>bpath</i> /cns/ <i>host</i> /cns.log. <i>x.n</i>	File	Name space event log file at destination <i>rhost</i> .
<i>rhost</i> : <i>bpath</i> /cns/ <i>host</i> /Inventory	File	Name space inventory at destination <i>rhost</i> .
<i>cwd</i> /[<i>name</i> /]cns/core	File	Core file (also set as the working directory).
<i>epath</i> /[<i>name</i> /]cns.log	File	Name space event log file.
<i>epath</i> /[<i>name</i> /cns/ <i>host</i> : <i>port</i> /cns.log. <i>x.n</i>	File	Name space event log file for destination <i>host</i> .
<i>lpath</i> /[<i>name</i> /]cnsdlog	File	Message log file.

⁷ Values shown as *xrootd* are obtained from the underlying **xrootd** server that started **XrdCnsd**.

⁸ This comes from the **-n** option specified when the underlying **xrootd** was started.

5.4 Listing Differences with `cns_ssi diff`

Use the following command to list differences between the composite name space and the inventory file maintained by **XrdCnsd**.

```
cns_ssi diff [-m] [-n] [-p] [-s] ipath npath [. . .]
```

Function

List the differences between the inventory file and the composite name space.

Parameters

ipath is the path that contains *all* of server file inventories. This should be the same path specified with the **-b** option for **XrdCnsd**.

npath is the root path of the composite name space on the current host. This is usually a redirector. If there is more than one root path (i.e., you have multiple exports) list all of the root paths. Names past the root path are treated as logical file names (lfn's).

Options

- m** checks file mode differences between the name space and inventory.
- n** checks space name differences between the name space and inventory.
- p** displays the physical file names as opposed to logical file names.
- s** checks size differences between the name space and inventory.

Defaults

None.

Notes

- 1) The name space starting with each *npath* is recursively indexed. The result is compared to all of the inventories rooted at *ipath*. One or more lines of output is produced for each discrepancy, as follows:

x host mode size name fn

where:

- | | |
|-------------|---|
| <i>x</i> | <ul style="list-style-type: none"> + if the file is in the inventory but not in the name space.
The displayed line comes from the inventory. - if the file is in the name space but not the inventory.
The displayed line comes from the local name space. > a difference exists in the mode, size, or space name.
The displayed line comes from the local name space. < a difference exists in the mode, size, or name.
The displayed line comes from the inventory. |
| <i>host</i> | the local host name(- or >) or the owning host name(+ or <). |
| <i>mode</i> | the expected(+), actual(-), local(>), or remote(<) access mode. |
| <i>size</i> | the expected(+), actual(-), local(>), or remote(<) size in bytes. |
| <i>name</i> | the expected(+), actual(-), local(>), or remote(<) space name. |
| <i>fn</i> | the logical file name or physical file name if -p was specified. |

- 2) A warning message is issued if there are outstanding log file that would make the inventory incomplete. You should first run **cns_ssi updt** to make sure you have an up-to-date inventory.

Example

```
cns_ssi diff /Inventory /Atlas
```

5.5 Listing the inventory with `cns_ssi list`

Use the following command to produce a formatted output of the file inventory maintained by `XrdCnsd`.

```
cns_ssi list [ options ] ipath  
options: [-h] [-l] [-m] [-n] [-p] [-s] [-S]
```

Function

List the file inventory maintained by the Cluster Name Space Daemon.

Parameters

ipath is the path that contains one or more server file inventories. This should be the same path specified with the `-b` option for `XrdCnsd`. All inventories in that path are displayed.

Options

- `-h` displays the owning server's hostname with each line of output.
- `-l` equivalent to specifying the `-h -l -m -n -p -s` options.
- `-m` displays the file creation mode and three octal digits.
- `-n` displays the space name (i.e., token) associated with the file.
- `-p` displays the path of the physical partition where the file resides on the owning server..
- `-s` displays the size of the file in bytes.
- `-S` displays the size of the file in human terms (i.e., bytes, K, M, G, or T).

Defaults

None.

Notes

- 1) **XrdCnsd** automatically creates a base inventory file should the server receiving the inventory not have one. Afterwards, the inventory file is logically maintained by co-locating update logs. You must physically update the inventory to get the current view. Use "**cns_ssi updt**" to physically bring the inventory file up-to-date prior to listing the inventory file.
- 2) If you list an inventory file that has outstanding updates, the listing's header line will indicate that the listing is "incomplete".
- 3) Normally, you will specify the path that was specified using **-b** option. This lists all inventories in that path. If you want to list a specific server's inventory, specify the server's qualified path. This path will be "**cns/shost**" where *shost* is the owning server's host name.

Example

```
cns_ssi list /atlas/Inventory
```

5.6 Updating the inventory with `cns_ssi updt`

Use the following command to bring the file inventory, maintained by `XrdCnsd`, up to date using any co-located log files.

```
cns_ssi updt [ options ] ipath  
  
options: [-v]
```

Function

List the file inventory maintained by the Cluster Name Space Daemon.

Parameters

ipath is the path that contains one or more server file inventories. This should be the same path specified with the `-b` option for `XrdCnsd`. All inventories in that path are displayed.

Options

`-v` increases verbosity to detail actions taken.

Defaults

None.

Notes

- 1) Use “`cns_ssi updt`” to physically bring the inventory file up-to-date prior to listing the inventory file using any co-located log files.
- 2) It is possible to periodically run updates using cron. The command guards against multiple updates running at the same time.

Example

```
cns_ssi updt /atlas/Inventory
```

6 Document Change History

26 October 2007

- New manual to document the **Cluster Management Service**.

1 December 2007

- Describe the **meta manager** attribute in the **manager** and **role** directives.

8 December 2007

- Describe the **seclib** directive.

8 January 2008

- Add documentation on **StartCMS** and **StopCMS**.
- Document the **prepmg** directive.
- General cleanup.

7 April 2008

- Document **trunc** under the **fsxeq** directive.

11 April 2008

- Document *min%* and *hwm%* in the **space** directive.

6 January 2009

- Correct description of the default **prepmg**.
- Change priority scale from 0-9 to 0-2.
- Deprecate **mps_prep** and **mps_PreStage** as **frm_psgta** and **frm_pstgd** have replaced them.

21 April 2009

- Document **XrdCnsd** and the **cns_ssi** command.

5 October 2009

- Document the **-L**, **-N**, and **-R** options of the **XrdCnsd** command.

17 November 2009

- Document the **-B** option of the **XrdCnsd** command.

17 March 2010

- Preferentially document '**all.pidpath**' as opposed to '**cms.pidpath**'.
- Minor text corrections.

26 April 2010

- Document **oss.space** directive instead of deprecated **oss.cache** directive.
- Document the new built-in prepare mechanism based on the File Residency Manager.
- Minor text corrections.

6 January 2011

- Document the '**ofs.osslib**' directive for **cmsd** use.

22 February 2011

- Document the '**cms.dfs**' directive for **cmsd** use.

8 March 2011

- Document the '**cms.delay qdl**' option.
- Document the **-b**, **-p**, and **-s** command line options.
- Document the **fwdwait** option of the **cms.request** directive.

6 June 2011

- Document the '**cms.delay qdn**' option.
- Document the '**cms.shed gsdflt**' option.
- Document the '**cms.shed gshr**' option.
- Document the '**cms.repstats**' directive.